

**INNOMAR MEDIUM**  
 TRANSDUCER FLANGE, M10  
 STUDS AT 1,3,5,7,9,11 O'CLOCK

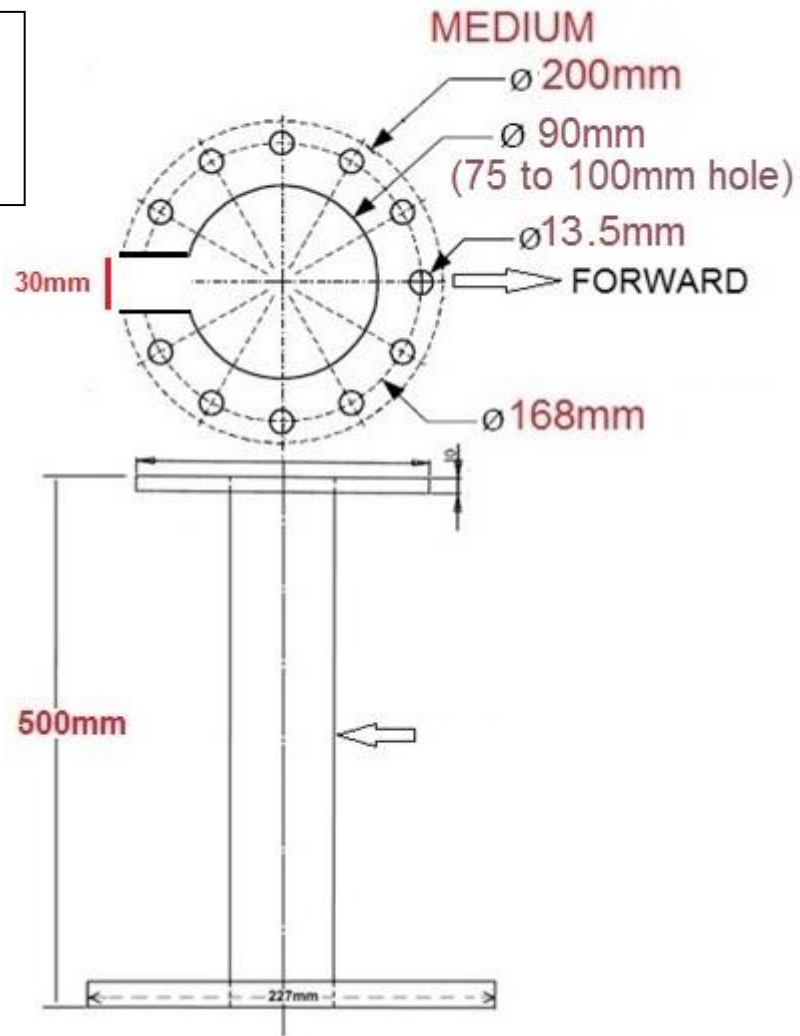

4" FLANGE USED ON  
 R2SONIC, RESON,  
 GEOSWATH,  
 KONGSBERG

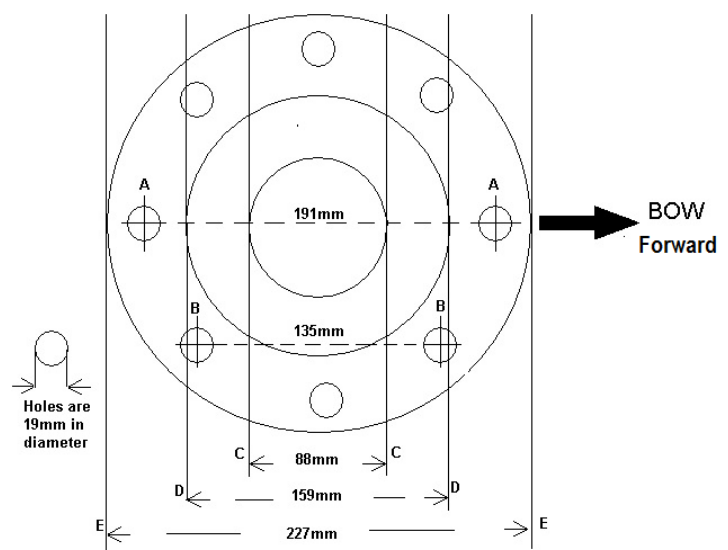

A-A = Distance between centres of any two opposite holes  
 B-B = Distance between centres of next holes out from centre  
 C-C = Diameter of hole through centre of pipe  
 D-D = Diameter of slightly raised lip on flange (2mm lip, see other diagram)  
 E-E = External diameter of flange