



MIDAS SVX2 Combined SV and CT Profiler Operating Manual



Document Ref: 06508136b
Date: Friday, November 2, 2018

This document was prepared by the staff of Valeport Limited, the Company, and is the property of the Company, which also owns the copyright therein. All rights conferred by the law of the copyright and by virtue of international copyright conventions are reserved to the Company. This document must not be copied, reprinted or reproduced in any material form, either wholly or in part, and the contents of this document, and any method or technique available therefrom, must not be disclosed to any other person whatsoever without the prior written consent of the Company.

Valeport Limited
St Peters Quay
Totnes
Devon, TQ9 5EW

Tel: +44 1803 869292
e mail: sales@valeport.co.uk | support@valeport.co.uk
Web: www.valeport.co.uk

United Kingdom

As part of our policy of continuous development, we reserve the right to alter, without prior notice, all specifications, designs, prices and conditions of supply for all our equipment.



1. Introduction.....	3
1.1. Contact Information.....	3
2. Specifications.....	4
2.1. Sensor Specifications.....	4
2.2. Mechanical Specifications.....	5
2.2.1 Dimensions.....	6
2.3. Performance Specifications.....	7
2.4. Sample Lifetime Calculations.....	8
2.4.1 Based on Memory.....	8
2.4.2 Based on Batteries.....	10
3. Installation.....	12
3.1. Communications With PC.....	12
3.2. Deploying the MIDAS SVX2.....	12
3.2.1 Real Time Operation.....	13
3.2.2 Self Recording Operation.....	13
3.2.3 LED Flashing Sequence.....	13
3.2.4 Real Time Data Formats.....	14
3.3. Recovery.....	14
4. Maintenance.....	15
4.1. Changing Batteries.....	15
4.2. Seals.....	16
4.2.1 O-Rings.....	16
4.2.2 Anti-Extrusion Rings.....	17
5. Wiring Information.....	18
5.1. Switch Plug.....	18
5.2. 3m Y Lead (RS232).....	18
5.3. 3m Switched Y Lead (RS485).....	19
6. Appendix 1: FAQ's.....	20

1. Introduction

This manual covers the specification, wiring details and basic maintenance procedures for the Valeport MIDAS SVX2 Combined SVP / CTD Profiler. Full details of how to operate the instrument with DataLog x2 software supplied are given in a separate manual.

As standard, the MIDAS SVX2 system consists of the following components:

- Titanium housed instrument
- Stainless steel deployment cage
- 3m Y lead (interface to PC)
- Switching Plug
- Basic maintenance tools and spare o-rings
- DataLog x2 Software CD
- Operating Manual
- Transit case

In addition, the following components may be supplied as optional extras:

- RS485 communications adapter
- FSK modem communications adapter (includes pcb in instrument)
- Various lengths & types of signal cable are also available

Instruments are often supplied (on request) with minor adjustments to the above list, such as a 5m Y lead instead of a 3m Y lead for example. Such variations will be detailed on the instrument packing list, and not in this manual.

1.1. Contact Information

If you have any questions about the operation of the instrument, which are not answered by this manual, please contact your supplier if appropriate, or contact Valeport Ltd directly at the address given at the front of this manual.

2. Specifications

2.1. Sensor Specifications

The unit is fitted with the following sensors:

Sound Velocity

Type:	Valeport "time of flight" sound velocity sensor
Range:	1375 to 1900m/s standard.
Accuracy:	$\pm 0.03\text{m/s}$
Resolution:	0.001m/s

Conductivity

Type:	Valeport inductive coils
Range:	0 - 80mS/cm
Accuracy:	$\pm 0.01\text{mS/cm}$
Resolution:	0.002mS/cm

Pressure

Type:	Temperature Compensated Piezo-Resistive Sensor
Range:	600Bar absolute (approx 6000m water depth) standard. Others available.
Precision:	$\pm 0.01\%$ Full scale ($\pm 0.6\text{m}$ with a 600Bar sensor)
Resolution:	0.001% Full scale (0.06m with a 600 Bar sensor)

Temperature

Type:	Fast response PRT
Range:	-5 to +35°C
Accuracy:	$\pm 0.01^\circ\text{C}$
Resolution:	0.002°C

2.2. Mechanical Specifications

Materials

Housing:	Titanium
Exceptions:	Sound velocity sensor uses carbon composite rods.
	Conductivity sensor is polyurethane and ceramic
Cage:	Stainless steel (316 grade) with polypropylene clamping brackets
Dimensions:	Instrument: 88mm Ø, 665mm long (including connector)
	Cage: 750mm long x 140mm x 120mm
Weight (in cage):	11.5kg (air), 8.5kg (water).
Depth Rating:	6000m (unless smaller pressure sensor fitted)

Connectors

Instrument:	10 pin female SubConn bulkhead type (MCBH10F) with lock ring.
Comms Cable:	Valeport 3m Y lead. 10 pin male SubConn line type (MCIL10M) to instrument, 2x 4mm bunch pins to external power, 9 pin female D type to PC.
Switch Plug:	10 pin male SubConn line type (MCIL10M), with lock ring. Note that the switch cap contains wiring links to activate the instrument.

The Switch plug is not a Dummy Plug

2.2.1. Dimensions

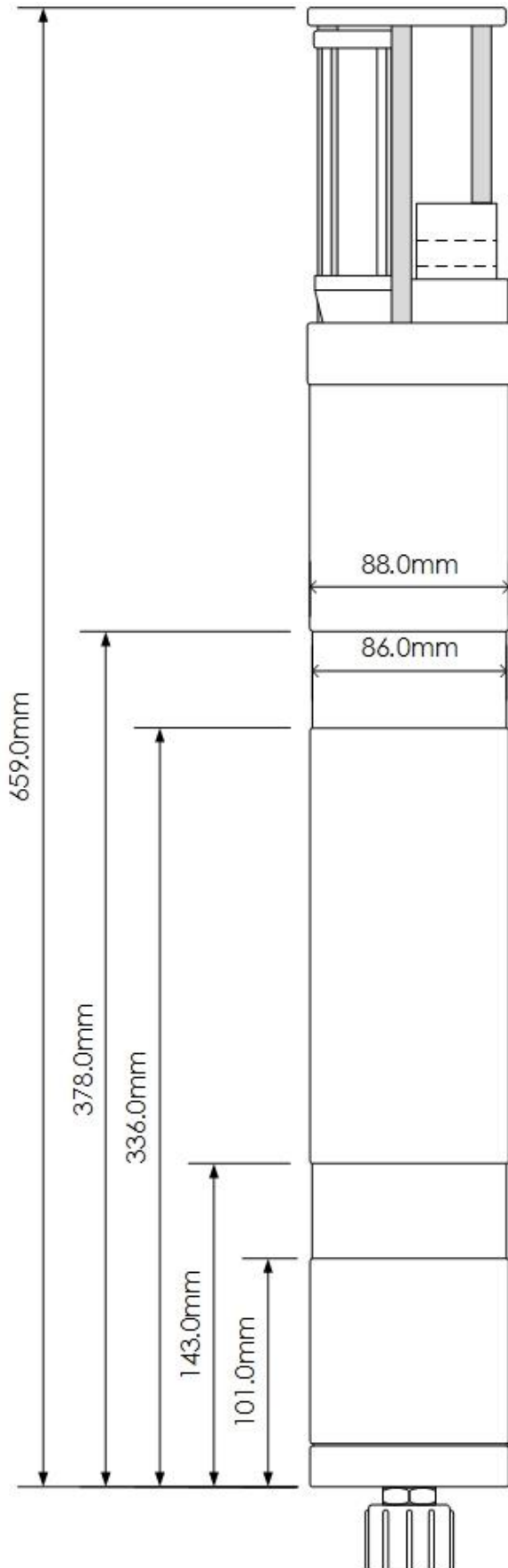

2.2.1.1. Pressure Sensor Offsets

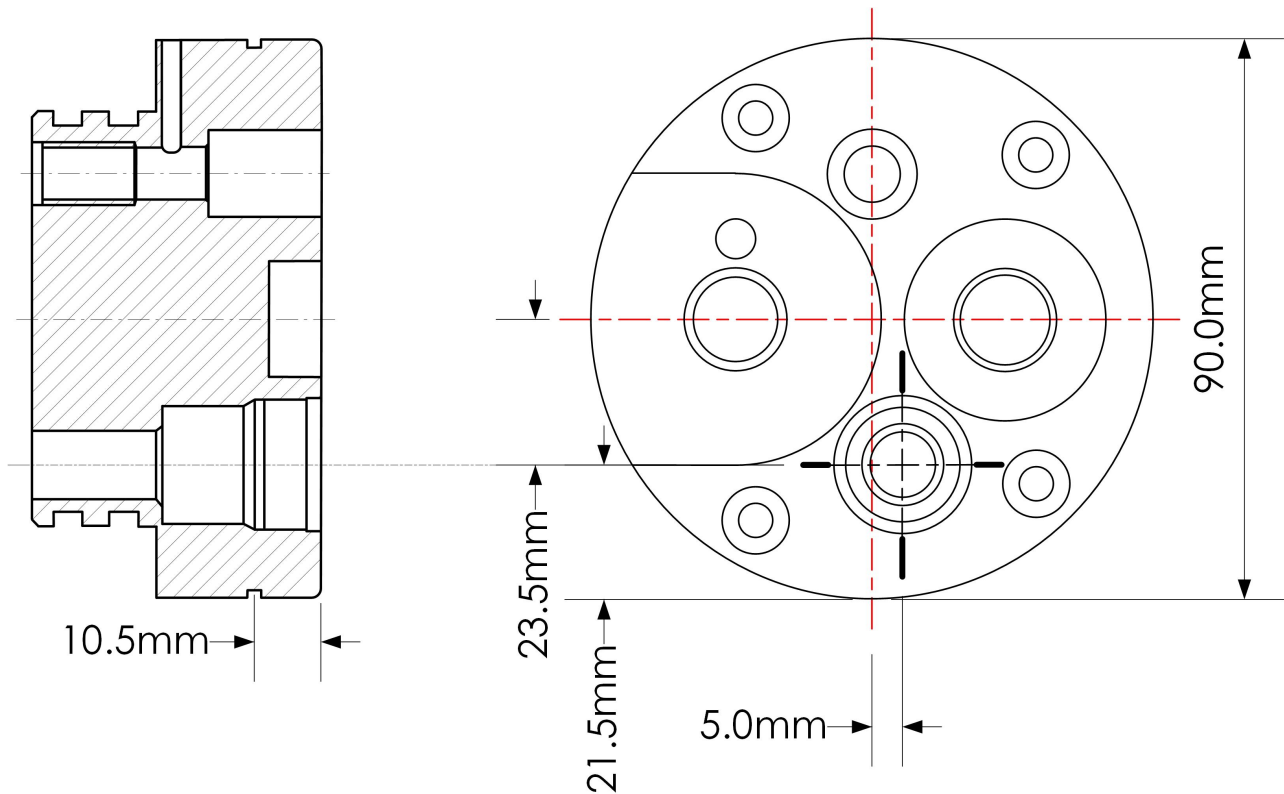

2.3. Performance Specifications

Memory:	16Mb solid state memory (upgradeable in 16Mb steps to 64Mb)
Internal Power:	8 x 1.5v alkaline C cells. The unit will accept 8 x 3.6v Lithium C cells with no alterations required Do not mix battery types
External Power:	Between 9 and 30v DC.
Current Drain:	~60mA at 12v when running, and 0.25mA when in sleep mode.
Sampling Rate:	1, 2, 4 or 8Hz (synchronised)
Data Output:	RS232 or RS485 depending on pin selection. Baud rate is user selectable from 2400 to 460800

2.4. Sample Lifetime Calculations

2.4.1. Based on Memory

Lifetime based on memory is simple to calculate. Conductivity, temperature and pressure values use 2 bytes of memory per sample, and sound velocity uses 4 bytes. Therefore total memory used per record is $4 + (3 \times 2) = 10$ bytes. Note that in Profile mode, each record is also assigned a date/time stamp, which uses a further 7 bytes.

The 16 Mbyte memory actually contains 16,777,216 bytes. Allowing a small amount of memory usage for header files, the memory will store almost 1 million records in Profiling mode, and over 1.6 million records in other modes.

The length of time that this memory will last for obviously depends on sampling scenario. Here are three examples:

Continuous Data Sampling, 8Hz:

Memory used per second is 10×8 bytes = **80 bytes**

Total memory fitted is **16,777,216 bytes**

Seconds before memory full is $16,777,216 / 80 =$ (approx) **209,700 seconds**

This is equivalent to **58 hours**

This period could be doubled by sampling at 4Hz

Burst Sampling, 4Hz:

sampling 1 minute in every 10, recording all data points:

Memory used per burst is $10 \text{ bytes} \times 4\text{Hz} \times 60 \text{ seconds} =$ **2 400 bytes**

The memory will therefore be full after $16,777,216 / 2400$ bursts = **6 990 bursts**

At a 10 minute cycle time, this is **69 900** minutes, which is equivalent to **48 days**

Profiling, 6000m cast, measuring every 1 metre:

In this example, the instrument will take 1 reading every metre of both descent and ascent. This means 6000 data points descending, and a further 6000 ascending. Each record consists of 10 bytes of data and 7 bytes of time stamp. Each record therefore uses **17 bytes**. A single cast will take 12,000 such records, and will therefore use **204,000 bytes**.

The 16Mbyte memory will therefore hold approximately **82 casts** of data.

2.4.1.1. A Note About Removable Memory

We are sometimes asked whether we offer these devices with removable memory. The answer is no we don't, but there are sound reasons for this. It is natural to think that since removable memory cards are now the norm in consumer electronics, they must be "state of the art" and therefore desirable in all applications, but this is not necessarily the case.

- An essential feature of an underwater instrument is that it is water-tight; this is achieved by using various seals on the mechanical parts of the device. Every time that one of these seals is broken and remade, it introduces a small risk that the seal is not correctly made, and the instrument could leak. The fewer times that the device has to be opened, the better – you certainly wouldn't want to do it after every profile to get the memory card out.
- All memory cards are susceptible to ESD shock (static electricity) while being handled. We take the view that the value of your data means it shouldn't be exposed to the possibility of this risk, which could result in loss of all data on the card.
- Memory cards are not particularly efficient at storing data – they will only accept minimum sized lumps of data at a time. This may be perfect for a camera where you instantly generate a few Mbytes, not so for an application where you only want to store a few bytes of data at a time.
- From a practical point of view, the time taken to connect a cable and extract the data to PC is actually typically much less than the time to open the device, remove the memory, replace the memory, and close the device up again.
- The implementation of removable memory is not technically difficult, but we believe that the disadvantages currently outweigh any possible advantages in this product and its applications. However, should circumstances change it will of course be considered for future product enhancements.

2.4.2. Based on Batteries

The MIDAS SVX2 will function with a voltage supply of between 9 and 30vDC. The voltage output of the 8 x C cell battery pack will vary according to the type of cell fitted. The most likely cells to be used will be standard alkaline type (1.5v each) or Lithium cells (3.6v each), giving a 12v nominal output for alkaline cells, or 28.8v nominal for Lithium cells. The following calculations are based on the same sampling scenarios as the memory calculations, using figures for a 12v alkaline battery pack. Each example also gives a figure for a Lithium battery pack, calculated from a basic ratio of alkaline to Lithium performance.

In all examples, it is taken that an 8 C cell alkaline battery pack will have a nominal capacity of 7.8Ah, and will be 75% efficient (total available charge, 5.85Ah), and that an 8 C cell Lithium pack will have a nominal capacity of 7.2Ah, and will be 95% efficient (total available charge, 6.8Ah).

Continuous Data Sampling, 8Hz:

At 12v, the instrument draws **60mA** when sampling.

Total charge available is **5 850mAh**.

Number of hours available is therefore 5850mAh / 60mA = **97 hours**.

This is equivalent to just over **4 days**.

For Lithium cells, a similar calculation gives around **11 days**.

Note: the instrument is effectively operating continuously when in Trip sampling mode, so similar calculations will apply.

Burst Sampling, 4Hz, Sampling for 1 Minute Every 10 Minutes:

At 12v, instrument draws 60mA when sampling, plus 60mA for 5 seconds at the start of each burst. It draws 0.25mA when in sleep mode between bursts.

In this scenario then, the instrument will draw 60mA for 65 seconds, and then 0.25mA for 535 seconds.

On average, it will draw:

$$\frac{(60 \times 65) + (0.25 \times 535)}{(65 + 535)} = 6.72\text{mA}$$

Total charge available is **5 850mAh**.

Number of hours available is therefore 5850mAh / 6.72mA = **870 hours**.

This is equivalent to approx **36 days**.

For Lithium cells, a similar calculation gives approx **100 days**.

The above examples are intended as guides only. Valeport cannot accept responsibility for variation in actual performance.

Note that performance of individual battery cells is not always consistent.

2.4.2.1. A Note About Rechargeable Cells

We are often asked if rechargeable cells can be used. Yes, it is possible to use rechargeable cells, but we do not recommend it:

- Firstly, the cells cannot be recharged in-situ due to the possibility of the cells giving out gas inside a sealed instrument, effectively turning it into an explosive device. Whilst this risk is small, it does exist and therefore must be considered. The risk could be overcome by adding an air vent to the housing, but this could compromise the water-tight nature of the housing. Better to remove the risk altogether.
- Secondly, the most commonly used rechargeable cells are NiCad type. These only operate at around 1.2v maximum and have about 25% of the capacity of an alkaline cell; they therefore give greatly reduced operating times.
- Modern Li-ion or NiMH cells are more efficient than NiCad cells, but do not yet compare with alkaline cells. They are also considerably more expensive.

Technology is constantly changing and battery technology, in particular, is at the forefront of development. As new battery chemistries become available Valeport will advise on a case by case basis.

3. Installation

The standard system is supplied in an ABS transit case, together with any communications adaptors ordered. Any additional lengths of signal cable are packed separately.

3.1. Communications With PC

The MIDAS SVX2 can be set up and interrogated using DataLog x2 software which is supplied with the instrument or can be downloaded from Valeport website. Please refer to the separate manual for details of how to use the software.

To connect the instrument directly to a PC for RS232 communications, use the 3m Y lead supplied. This lead is fitted with a 10 pin SubConn type connector, which should be plugged directly into the connector on the top of the housing (or to a length of signal cable). The lead also features 2 x 4mm bunch pins for application of external power if required and a 9 way D type connector which should plug directly into a spare communications port on the back of the PC.

If non-RS232 communications are to be used, via the optional RS485, RS422 or FSK methods, then the appropriate adaptor should be used. Each adaptor is supplied with an alternative Y lead, which should be connected as follows:

Comms Method	Adaptor Part No.	Connections
RS485	0400029	Connect 15 pin D type and 4mm plugs from Y lead into adapter. Connect 9 pin D type from adapter to PC, and 4mm plugs from adapter to external power, as indicated on adapter housing.
FSK	0400005	Connect 4mm plugs from Y lead into adapter, leaving D types unconnected (FSK uses power and signal on just two wires). Connect 9 pin D type from adapter to PC, and 4mm plugs from adapter to external power, as indicated on adapter

3.2. Deploying the MIDAS SVX2

All parts of the standard system (with the exception of the top part of the 3m Y lead) are designed for immersion. All communications adaptors (RS485, RS422, FSK) are splash proof, but should be sited in a dry place, as close to the PC as possible.

The MIDAS SVX2 is supplied with a stainless steel protective cage, but care should still be taken not to damage the instrument. For profiling work, the recommended deployment method is to suspend the instrument using the stainless steel wire stop fixed to the top of the cage. For fixed deployments, the user may wish to remove the cage, and use the grooves in the instrument housing as clamping points.

3.2.1. Real Time Operation

For real time data output, connect the signal cable to the 10 pin SubConn connector on the instrument. All Valeport signal cables include a suspension point for strain relief, and a similar arrangement is recommended for other cable types. Connect the top end of the cable to a PC using the appropriate method as described above.

3.2.2. Self Recording Operation

For self recording only deployments, the instrument is switched on by insertion of the SubConn style switch plug. This plug must be inserted for the unit to operate.

The switch plug is NOT just a dummy plug; it contains links between pins as described in Section 5, which are used to turn the instrument on.

3.2.3. LED Flashing Sequence

The MIDAS SVX2 is fitted with an LED visible through a polycarbonate window in the battery pack. The LED will flash as detailed below to indicate various states.

Continuous ON for 15 seconds	Occurs when the Switch Plug or cable is connected, indicating that instrument is on and awaiting communication
1Hz Continual Flashing	Insufficient Power. Change internal batteries, or completely remove external power, and apply higher voltage
Continuous ON for 2 seconds	Indicates the start of Burst Sampling pattern
5 Rapid Flashes	Indicates the end of Burst Sampling pattern. The duration of the burst may be calculated as the time between the start and stop LED sequences, less 5 seconds.

3.2.4. Real Time Data Formats

Sound Velocity<TAB> Units<TAB> Depth<TAB> Units<TAB> Temperature<TAB> Units<TAB>
 Conductivity<TAB> Units<TAB><CR><LF>

Example:

1483.576	M/SEC	0010.122	M	0021.291	C	0000.142	MS/CM
1483.578	M/SEC	0010.122	M	0021.293	C	0000.140	MS/CM
1483.578	M/SEC	0010.121	M	0021.284	C	0000.142	MS/CM
1483.581	M/SEC	0010.122	M	0021.287	C	0000.140	MS/CM

If internal salinity calculation is activated:

Sound Velocity<TAB> Units<TAB> Depth<TAB> Units<TAB> Temperature<TAB> Units<TAB>
 Conductivity<TAB> Units<TAB>Salinity<TAB>Units<TAB><CR><LF>

1483.576	M/SEC	0010.122	M	0021.291	C	0000.142	MS/CM	0000.124	PSU
1483.578	M/SEC	0010.122	M	0021.293	C	0000.140	MS/CM	0000.122	PSU
1483.578	M/SEC	0010.121	M	0021.284	C	0000.142	MS/CM	0000.124	PSU
1483.581	M/SEC	0010.122	M	0021.287	C	0000.140	MS/CM	0000.122	PSU

3.3. Recovery

On recovery, data can be extracted to PC via the 3m Y lead. This procedure is covered in the separate software manual for DataLog x2.

To prolong the lifetime of the instrument the following procedures should be carried out once the instrument has been recovered:

- Remove any significant growth from the instrument, taking care not to damage transducer face or reflector plate of the sound velocity sensor, and paying particular attention to the core of the conductivity sensor. A high pressure water jet or stiff (not metal) brush is suitable – a hard toothbrush is ideal.
- Remove any significant growth from the pressure sensor port. Take care not to introduce any sharp objects onto the sensor face – this may result in sensor damage.
- Check instrument for signs of damage.
- Rinse the instrument in fresh water
- Dry the instrument if possible, paying particular attention to the sensors and connector.
- Repack the instrument in the transit case provided.

4. Maintenance

The MIDAS SVX2 is completely solid state, and therefore requires very little maintenance. Other than keeping the instrument relatively clean (as described in Section 3.3, Recovery), the only procedure that the customer will be required to carry out on a regular basis is to change the batteries. This Chapter also covers details of the o-rings that are fitted to the instrument, and which should be checked periodically for damage and replaced if necessary.

4.1. Changing Batteries

The MIDAS SVX2 accepts 8 x C cells, of either 1.5v alkaline or 3.6v Lithium type. These cells are arranged in series, so the output voltage is 12v (alkaline) or 28.8v (Lithium). Some example scenarios for lifetime of these batteries are given in Chapter 2.4.2

The batteries are located in a holder in the top of the instrument, and should be accessed by removing the connector bulkhead.

1. (This step may be omitted)

For easier access, remove the instrument from the protective cage by loosening the M10 nuts on the polypropylene clamps. Gently lever these clamps apart, using a screwdriver if necessary.



Slide the instrument out of the cage, in either direction.



2. Remove the 3 M5 x 20 socket cap screws in the connector bulkhead, using the Allen key provided. Note that these screws are titanium, and should be replaced with titanium screws if lost. Other materials may suffer galvanic corrosion and may be destroyed.
3. Without twisting or putting undue stress on the SubConn connector slide the bulkhead and attached battery pack out of the main housing. A slot between the tube and the bulkhead allows levering with a screwdriver if necessary. Take care not to scratch the bore of the tube.



4. A lead connects the battery pack to the electronics inside the tube. This may be disconnected at the battery pack if required, for ease.
5. Replace the batteries.
6. Check the condition of the bore seal o-rings, and apply a light coating of silicon grease. Ensure that both they and the anti-extrusion rings sit in the groove correctly, and are free from damage. Replace them if necessary (refer to Section 4.2).
7. Reattach the connector to the electronics if necessary, and gently slide the battery pack back into the tube, ensuring that the fixing holes are correctly aligned. Again, take care not to scratch the bore.
8. Replace the 3 x M5 titanium screws, using a small amount of copper grease (supplied). Do not force the screws, just tighten firmly.
9. Finally, slide the instrument back into the protective cage. Note that the clamping brackets are offset, and that the sensor end of the instrument should lie at the long end of the cage.

4.2. Seals

The MIDAS SVX2 is kept watertight by using o-ring seals and anti-extrusion rings. Double o-ring seals are used at each end of the titanium housing, although the customer should have no reason to open any seal other than that at the battery end.

A set of spare o-rings and anti-extrusion rings is included with the equipment. If an o-ring needs replacing, be sure to use the correct size. If obtaining further spare o-rings from an alternative source, be sure to obtain the correct material (signified by the last 4 digits of the o-ring code number).

O-ring size:	200-143-4470
Anti-extrusion ring size:	143

4.2.1. O-Rings

To help preserve the watertight nature of the equipment, please observe the following guidelines:

- Ensure that all o-rings are free from cuts, abrasions or perishing.
- Ensure that all-o-rings are free from dirt, grit, sand, hair and other foreign objects.
- Ensure that an anti-extrusion ring is fitted on the low pressure side of each o-ring (see Section 4.4.2)
- Whenever an o-ring seal is opened (e.g. when changing batteries), ensure that a light coating of silicon grease is applied to the o-ring before the seal is closed.
- Ensure that all o-ring protected seals are tightened.

4.2.2. Anti-Extrusion Rings

It is common Valeport practice to fit Anti-Extrusion Rings, also known as AE Rings or Backing Rings, to o-ring seals on deep water instrumentation.

The function of an AE Ring is to prevent the o-ring from being squeezed out of its groove under high pressure. Whilst this may not immediately cause a leak, it can damage the o-ring to the extent that it will not properly seal on subsequent deployments.

Where an AE ring is fitted, Valeport favour a single solid ring type made from nitrile rubber. These are black or dark grey in appearance, and are distinguishable from the o-ring itself by having a square cross-section, with a single concave surface, as illustrated:



These rings should be fitted into the o-ring groove on the "dry", or low pressure side of the o-ring, with the concave surface adjacent to the o-ring itself:

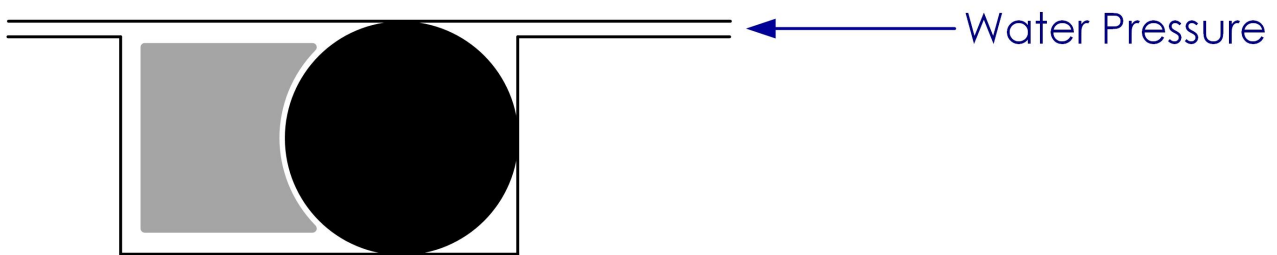

It is particularly important to note that in order to fit these rings, they must be stretched slightly to pass over the instrument body. This stretch does not immediately recover, with the result that the AE ring may not sit snugly in the groove at first. Fitting the tube to the instrument at this point may result in the AE ring riding out of the groove, and preventing a proper seal. The instrument may then leak.

Once an Anti-Extrusion ring has been fitted, please leave a minimum of 30 minutes for it to recover its shape before fitting the tube.

5. Wiring Information

5.1. Switch Plug

10 Way Male SubConn	Function
1	Link to Pin 10
2	NC
3	NC
4	NC
5	NC
6	NC
7	NC
8	NC
9	NC
10	Link to Pin 1

5.2. 3m Y Lead (RS232)

10 Way Male SubConn	1m Power Cable	4mm Banana Plugs	9 Way D Type	Function
1	BLUE	BLACK		Power Ground
2	BROWN	RED		Power +V
3				
4				
5				
6				
7			2	RS232 Tx (To PC)
8			3	RS232 Rx (From PC)
9			5 (link to 1,6,8,9)	RS232 Ground
10			SHELL	
				Internal Battery Enable Link to RS232 Ground

5.3. 3m Switched Y Lead (RS485)

10 Way Male SubConn	SWITCH BOX	1m White Cable	4mm Banana Plugs	15 Way D Type	9 Way D Type	Function
1		BLUE	BLACK			Power Ground
2		BROWN	RED			Power +V
3				9		RS485 A
4				10		RS485 B
5				11		
6				12		
7					2	RS232 Tx (To PC)
8					3	RS232 Rx (From PC)
9				5	5 (link to 1,6,8,9)	RS232 Ground
			SHELL	SHELL		
10					Internal Battery Enable	

6. Appendix 1: FAQ's

Why is the SV data from the time of flight sensor different from the CTD data?

Quite simply, the Valeport SV sensor is more accurate than the CTD data. This is because the CTD formulae (Chen & Millero, Del Grosso etc.) all have errors in them – they were after all based on observed data taken over 30 years ago using the best technology available at the time. The Valeport SV sensor simply highlights those errors.

The purpose of this product is actually to provide you with good SV data as well as Density and Salinity data, which were not previously available on an SVP. The ability to compare the true sound velocity with the value calculated from CTD is an obvious consequence of this, and raises questions that had not been previously considered.

Why is the SV data so accurate?

Several reasons. Primarily, we use an advanced digital signal processing technique that removes virtually all noise from the data, tells us the precise moment that the sound pulse is both transmitted and received, and allows us to measure the time of flight with a resolution of 1/100th of a nanosecond (10-11 seconds). Secondly, we have developed a carbon composite material that doesn't expand or contract with temperature, so our "known distance" is a constant. Technically, the material will expand and contract minutely, but over the operating temperatures of the probe, it is an almost immeasurably small amount, and any change is included in our overall error budget. Finally, our calibration method removes virtually all the error sources associated with other techniques.

But don't you just calibrate it against Chen & Millero?

No we don't – that would defeat the purpose. While the seawater formulae (Chen & Millero, Del Grosso etc.) have inherent errors that are accepted as being at best $\pm 0.25\text{m/s}$, we use a different formula to calibrate the sensor. Del Grosso also published a formula for speed of sound in pure water (with Mader, 1972), which is much more accurate. In pure water, the only variable that can affect sound velocity is temperature (assuming that you are at atmospheric pressure in a laboratory environment), rather than both temperature and Salinity with the seawater equations. The Del Grosso & Mader formula therefore has an error of just $\pm 0.015\text{m/s}$. By calibrating against this rather than against the error-filled seawater equations, we can achieve significantly better performance.

Is a pure water calibration valid?

Absolutely – the purpose of a calibration is just to compare (and adjust) the sensor output against a known standard – it doesn't really matter what that standard is, as long as it is precisely defined. Our standard happens to be pure water because it is the most accurately defined standard available.

How Robust is the Conductivity Cell? It looks like it's made of plastic.

We wouldn't go so far as to say it's indestructible, but it is pretty strong. It's actually made from titanium, with just a thin coating of polyurethane to insulate it. The key thing is the central core, which is a specialised ceramic material that is particularly durable. It allows the sensor to overcome a common failing of inductive cells, which is that they rely on the dimensions of the central core remaining absolutely constant. As pressure increases, most inductive cells compress slightly, so they may be out of specification at high pressure. The strength of Valeport's cell keeps the dimensions remarkably stable, so performance is maintained over the entire profile.

I've Fixed it to my ROV and I'm Getting Strange Readings - Why?

There are three possible causes of this. Firstly, check that nothing else on the ROV is physically interfering with the conductivity sensor, for example a cable lying across the cell. Anything that

intrudes on the electrical fields (which extend about 5cm around the cell) may affect the readings, although this is unlikely to be a significant enough effect to give you cause for alarm in the first place.

Secondly, check that the instrument is not positioned adjacent to a source of electro-magnetic interference such as a thruster or other motor. These can generate large electrical fields that may disrupt the conductivity sensor. This problem usually manifests as an intermittent fault, coinciding with the thrusters being turned on and off.

Finally, consider the possibility that something on the ROV is actually changing the local water conditions. A good example is a lighting array actually heating the surrounding water. A device positioned near this will measure the warmer water, and consequently may give elevated SV, temperature and / or conductivity readings. A good check for this is to observe the Salinity data, which should remain reasonably constant regardless of whether the temperature and conductivity readings are different from those expected.

Is Conductivity Affected by Growth?

Yes, growth will change the conductivity readings. However, the most important thing is to keep the central core of the sensor clean. You are unlikely to notice any significant change from a small amount of growth on the outside of the cell.

How Often Does it Need Calibrating?

The SV sensor itself is remarkably stable. Since the entire timing system is digital, it is not subject to the drift that analogue components often exhibit over time. The only part of the system that can drift with time is the timing crystal itself. This is typically less than $\pm 0.005\text{m/s}$ in the first year, and less than $\pm 0.002\text{m/s}$ in subsequent years. We quite confidently say that the SV sensor should remain within specification for several years. However, the conductivity, temperature and pressure sensors that are also fitted to the profiler do exhibit greater drift with time. It is our experience that in the majority of cases, performance can be maintained by recalibrating at 2-yearly intervals. However, we are aware that many operators' own QA requirements state annual recalibration, and it is true that most instruments are returned to us on a yearly basis.

The Downcast Seems Fine, But Why is the Up Cast Sometimes Different?

Again, there are three points to consider. Firstly, did you drop the instrument into the bed? If it has picked up debris on the SV sensor then the sound pulse may be reflecting off something other than the reflector face, sediment in the conductivity cell will affect the readings, if the temperature sensor is caked in mud its response time will be slowed, and if the pressure sensor is blocked then it may not perform at all.

Secondly, note that we suggest profiling with the sensors pointing downwards. The water will flush through them better on the downcast than the up cast, so this may result in minor variations between the up and down parts of the profile.

Finally, consider the possibility that the conditions have changed. The oceans change in time as well as depth, so perhaps there has been a shift between the down and up cast. We have seen several sets of data that show variations in down and up cast occurring on both time of flight and calculated SV data. Since these are effectively independent measurements, it is logical to conclude that the variations may actually exist.

How fast can I profile?

The profiler runs at 8Hz, and in free fall will achieve a drop rate of perhaps 2m/s. Falling at this rate, it will cover 0.25m between readings, so provided the profile is set to take a reading at a greater increment than this, it will function correctly.

The SV Sensor Outputs Zero Sometimes – Why Is That?

The sensor outputs zero when it doesn't record the returning sound pulse within the expected time frame (a time frame that equates to 1400 – 1600m/s in terms of sound velocity). The most common occurrence of a zero value is when the sensor is in air, but it can also happen if the probe has been dropped into a soft bed and is covered in mud or sediment. This will normally wash off during the up-cast. It can also happen if the sensor has been deployed for some time without cleaning, and there is significant growth on the sensor.