

MINI SOUNDER

USER MANUAL

D101-04917
Revision 2
November 2013

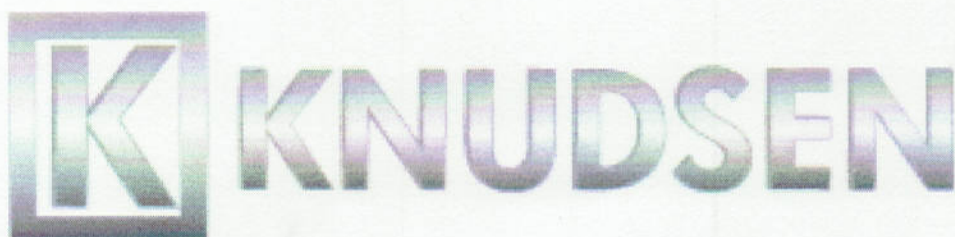

Knudsen Engineering Limited
10 Industrial Road
Perth, Ontario, Canada
K7H 3P2
Phone: 613-267-1165
Fax: 613-267-7085

www.knudseneng.com
info@knudseneng.com

Supplied by
GSE Rentals Ltd.
Aberdeen, Scotland, UK.
Email: info@gserentals.co.uk
Http: www.gserentals.co.uk

CONTENTS

1	INTRODUCTION	3
1.1	About this manual	3
1.2	Technical Support	3
1.3	Unpacking Shipment	3
2	DESCRIPTION	4
2.1	System Overview	4
2.2	Physical Characteristics	4
3	INSTALLATION	5
3.1	System Overview	5
3.2	Software Installation	5
3.3	Connector Panel Overview	5
3.3.1	Input Power	5
3.3.2	Power Switch	5
3.3.3	Power Indicator	5
3.3.4	Transmit (TX) Output	6
3.3.5	USB Interface	6
3.4	System Connection	6
3.4.1	Peripherals	6
3.4.2	Data Logging	6
3.5	Transducer Installation	6
3.5.1	Over-the-Side	6
3.5.2	Through Hull	7
3.5.3	Sea Chest	7
4	SYSTEM OPERATION	8
4.1	Factory Setup	8
4.2	Basic Controls	8
4.2.1	Shallow Water Hints	8
4.2.2	Deep Water Hints	8
5	TROUBLESHOOTING	9
5.1	Power Indicator is Off	9
5.2	No Output to Transducer	9
5.3	No Connection to PC	9
6	CABLE CONNECTIONS	10

1 INTRODUCTION

1.1 About this manual

This manual describes the basic setup and operation of the Mini Sounder.

1.2 Technical Support

For technical support or to report problems please contact your local representative or:

Technical Support
Knudsen Engineering Limited
10 Industrial Road
Perth, Ontario
K7H 3P2

Voice: (613) 267-1165 8:30 am to 5:00 pm E.S.T. Core Hours

Fax: (613) 267-7085

E-Mail: support@knudseneng.com

WebSite: <http://knudseneng.com/>

1.3 Unpacking Shipment

The Mini Sounder is securely packed in a plastic shipping/storage case. In the standard shipment will be the following items:

- Mini Sounder Echosounder
- DC power cable
- Transducer cable connector(unless already installed on transducer)
- USB cable
- SounderSuite Software CD-ROM
- Mini Sounder User Manual

2 DESCRIPTION

2.1 System Overview

The Mini Sounder is a portable, low cost, entry level system ideal for shallow water to mid-depth surveys. It is a single channel system that the user can configure to any frequency between 24kHz and 210kHz allowing water depths from 15cm up to 1000M (transducer dependant).

Multiple Mini Sounder systems allow the user the flexibility of having a dual channel system (ex 28/200kHz) on one day for sub bottom tracking and two single channels systems the next day for multiple vessel surveys.

2.2 Physical Characteristics

Outline drawings showing external dimensions, locations of connectors and controls, and location and specification of mounting points are located later in this manual. A summary of significant dimensions and weights of the Echosounder follows:

Length	257 mm
Width	158 mm
Height	89 mm
Weight	less than 3kg



3 INSTALLATION

3.1 System Overview

The Mini Sounder is a “black box” echosounder that utilizes a PC to allow the user to control all system parameters, manage peripherals, record entire echogram data, as well as internal and external data logging. The communication link from the Mini Sounder to the PC is via USB (full speed 2.0).

3.2 Software Installation

Once installed in the CD-ROM drive of your PC the SounderSuite-USB installation wizard will guide the user through the installation. For a more detailed explanation of the entire software installation please refer to the following manual:

SounderSuite - USB Windows Installation and Firmware Upgrades (part number D101-04383)

3.3 Connector Panel Overview



3.3.1 Input Power (DC IN)

The Mini Sounder needs to be powered from a DC source. The input voltage range is 12-30 VDC (nominal 24VDC). The power consumption of the Mini Sounder at startup is 20W with an average operating consumption between 15W and 18W.

3.3.2 Power Switch

When the power switch is placed in the “1” position it will pass the input voltage to the internal modules. When it is placed in the “0” position, power to the internal modules will be terminated. The power switch also has a built in circuit breaker for protection.

3.3.3 Power Indicator

This green indicator LED will illuminate when the proper input voltage has been applied to the Mini Sounder and transferred to the internal modules.

3.3.4 Transmit Output (TX OUT)

The TX Output connection transfers the high voltage transmit output signal to the transducer as well as the return echo to the echosounder. **CAUTION:** Make sure that the Mini Sounder is not transmitting while connecting or disconnecting the transducer to the Tx Output connection.

3.3.5 USB Interface

The USB interface provides communication from the Mini Sounder to the PC. It is a full speed 2.0 (12Mbps) connection. The connection is a waterproof IP68 “B” type but will mate with any standard USB cable.

3.4 System Connection

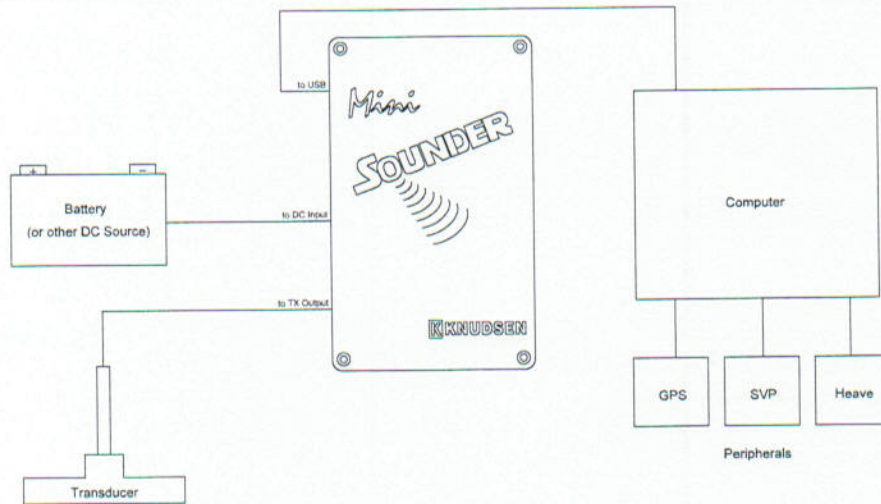

3.4.1 Peripherals

All peripherals are connected directly to the PC and the setup for each is via the EchoControl Client software application.

3.4.2 Data Logging

Same as the peripherals, any connection to an external data logger is done through the PC. There also is the capability to run the data logging package on the same PC that your EchoControl software is operating on.

3.5 Transducer Installation

The correct transducer installation is essential to maintain good system performance. There are three common types of transducer installations:

- 1) Over-the-side
- 2) Through Hull
- 3) Sea Chest

3.5.1 Over-the-Side

The method of mounting the transducer over the side of the boat is primarily used for temporary installations. This

usually entails the transducer mounted to the end of a pole that is fastened to the side of the boat. The majority of the transducers that are sold by Knudsen Engineering Limited have the option to be purchased with a mounting adapter. The adapter provides a small mounting stem made of a 1-1/4" aluminum pipe with a standard pipe thread. The longer pipe and the means to fasten it to the boat are not provided as they change with every installation. It is very important that the transducer will be completely submerged below the water surface at all times.

3.5.2 Through Hull

A more permanent means of mounting the transducer is through the hull. This will require modifications to be made to the hull of the boat. The face of the transducer will become the "wet end" in direct contact with the water and the cable end of the transducer will become the "dry end" inside the hull of the boat. The location of where the transducer goes through the hull has to be selected to prevent any type of aeration coming in contact with the transducer face. Any modifications that are to be done to the boat to install the transducer through the hull should be made by a qualified individual.

3.5.3 Sea Chest

Another permanent means of transducer installation is using a sea chest. The chest is located on the inside of the hull and the transducer transmits and receives either through the hull itself or through an acoustic window. The sea chest will need to be filled with water and may need a stand pipe to provide proper pressure to the transducer to avoid cavitation. The following illustration is an example of a sea chest transducer installation.

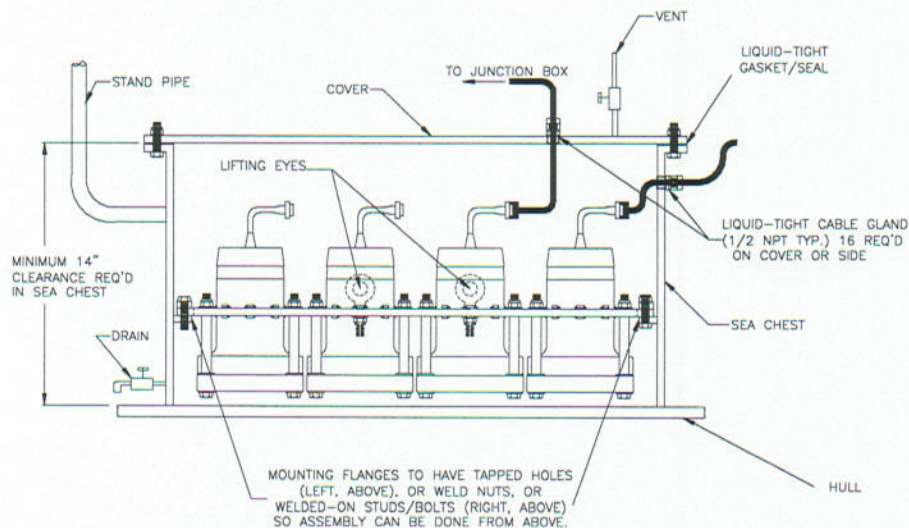

4 SYSTEM OPERATION

Your PC will automatically recognize the Mini Sounder upon power up. The SounderSuite installation CD will have installed applications shortcuts to the desktop of the PC. The EchoControl Server application needs to be started first and once running a "K" will appear in the task bar. After the EchoControl Server is running the EchoControl Client application can be started. NOTE : Running EchoControl Client will auto-run EchoControl Server. For a complete explanation on the operation of the EchoControl Server and EchoControl Client please refer to the following manual: *SounderSuite - USB EchoControl Client (part number D101-04380)*

4.1 Factory Setup

The Mini Sounder features a frequency agile channel that the user can configure to any frequency between 24 and 210kHz. The Mini Sounder's operating frequency will be preset at the factory to match a specific transducer, either supplied with purchase or requested by purchaser.

4.2 Basic Controls

For a complete explanation of all EchoControl Client controls please refer to the following manual: *SounderSuite - USB EchoControl Client (part number D101-04380)*

Some of the basic controls that the user will need to understand to operate the Mini Sounder are Tx Power, Gain, Pulse Length, Range, Phase, and Tx Blanking.

The Tx Power, Gain, and Pulse Length directly affect the strength of the output signal and thus the return echo. There are four power settings each approximately 25% of the configured total output power. The Gain can be selected manually or automatically (recommended). Shorter pulse lengths are to be used in shallow waters and longer pulse lengths in deeper water. Longer pulse lengths may be used in shallow water if the user is sub-bottom profiling.

The Range and Phase settings will tell the echosounder what the extents of the search window are. The Range determines the size of the search window and the Phase determines where in the water column to search. For example: (assuming Meters as units) Range 100 Phase 1

The search window will be from 0 to 100M. If the Phase changes to 2 the search window will shift down the water column and now be 50-150M. The same amount of information (100M) remains as the Range did not change. There is an AutoPhase control that will allow the echosounder to change to the proper phase as the bottom approaches either extent of the search window.

The Tx Blanking setting allows the user to block out any transducer ringing near the surface that may appear as a return and possibly confuse the system's bottom tracking. The Tx Blanking can be set by observing the amount of ringing present on your data when in a primary search window (0-10, 0-50, etc).

4.2.1 Shallow Water Hints

For operation in shallow water set the Power setting to 1 or 2. Set the Gain to AGC (Automatic Gain Control) and set the pulse length to its lowest setting. Make sure that the Tx Blanking settings is at a level that will function in your desired water depth. Set your Phase to 1 and your range to a level just larger than your desired water depth.

4.2.2 Deep Water Hints

For operation in deeper water you need to increase your Power to a level of 3 or 4. Leave the Gain set to AGC and increase your pulse length. The Tx Blanking setting should also be increased as the higher power and longer pulse

lengths will increase the transducer ringing.

5 TROUBLESHOOTING

5.1 Power Indicator is Off

Confirm proper input voltage applied to echosounder. If the input is okay then connect to PC to confirm operation. It may be that the LED has failed. If problem continues, contact Knudsen Engineering Limited.

5.2 No Output to Transducer

Confirm that the proper transducer has been connected to the echosounder. Then check the transducer cable for any bends, breaks, or other visible damage.

5.3 No Connection to PC

The Mini Sounder will be automatically recognized by Windows upon successful communication. If the Power Indicator is ON but the system is not recognized by the PC then first try changing USB cables and then try a different USB port on the PC. If the problem continues, contact Knudsen Engineering Limited.

6 CABLE CONNECTIONS

TRANSMIT OUTPUT

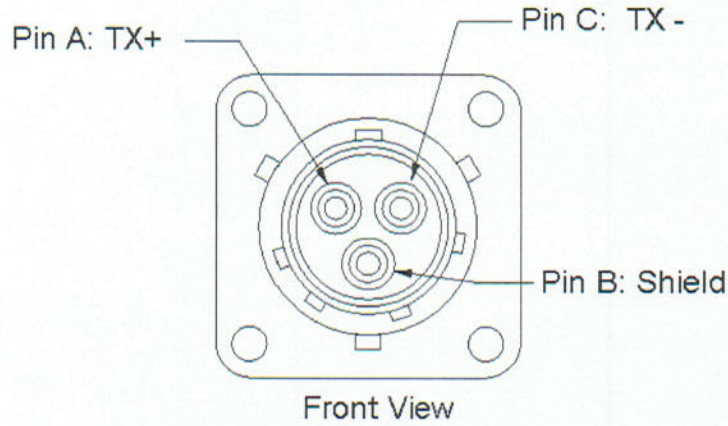

Bulkhead Connector: MS3470L12-3S
Mating Cable End: MS3476L12-3P
(or equivalent)

DC INPUT

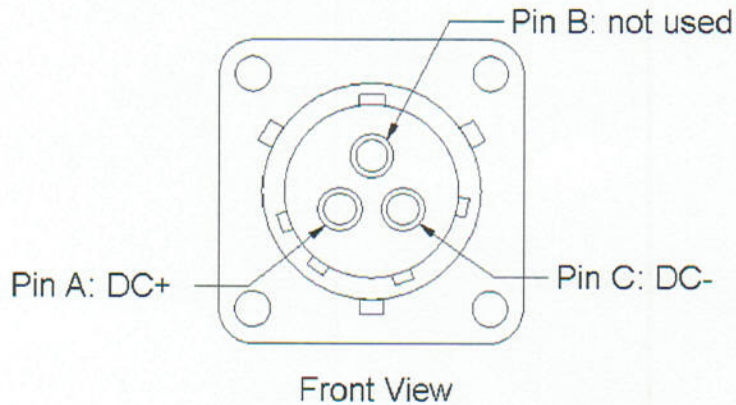

Bulkhead Connector: MS3470L12-3PY
Mating Cable End: MS3476L12-3SY
(or equivalent)