

# **Altimeter Product Manual**

## **Covering PA200, PA500 and LRPA**

0286-SOM-00001, Issue: 04

**Outstanding Performance in Underwater Technology**



© Trittech International Ltd.

The copyright in this document is the property of Trittech International Ltd. The document is supplied by Trittech International Ltd on the understanding that it may not be copied, used, or disclosed to others except as authorised in writing by Trittech International Ltd.

Trittech International Ltd reserves the right to change, modify and update designs and specifications as part of their ongoing product development programme.

All product names are trademarks of their respective companies.

## Table of Contents

<a href="#">Help &amp; Support</a>	<a href="#">4</a>
<a href="#">Warning Symbols</a>	<a href="#">5</a>
<a href="#">1. Specification</a>	<a href="#">6</a>
<a href="#">1.1. Notes on Specifications</a>	<a href="#">6</a>
<a href="#">1.2. Dimensions</a>	<a href="#">7</a>
<a href="#">1.3. PA200/PA500 Electrical and Acoustic</a>	<a href="#">10</a>
<a href="#">1.4. PA200/PA500 Physical and Environmental</a>	<a href="#">10</a>
<a href="#">1.5. LRPA Electrical and Acoustic</a>	<a href="#">11</a>
<a href="#">1.6. LRPA Physical and Environmental</a>	<a href="#">11</a>
<a href="#">2. Introduction</a>	<a href="#">12</a>
<a href="#">3. Installation</a>	<a href="#">13</a>
<a href="#">3.1. Optimal Orientation</a>	<a href="#">13</a>
<a href="#">3.2. Mounting Material and Suitable Brackets</a>	<a href="#">13</a>
<a href="#">3.3. Long Term Use</a>	<a href="#">13</a>
<a href="#">3.4. Standard Pin-Out Diagrams</a>	<a href="#">13</a>
<a href="#">4. Operation</a>	<a href="#">16</a>
<a href="#">4.1. General Guidelines</a>	<a href="#">16</a>
<a href="#">4.2. Output Strings</a>	<a href="#">16</a>
<a href="#">4.3. Data Stream Characteristics</a>	<a href="#">17</a>
<a href="#">4.4. Seanet Pro and SeaKing or Super SeaPrince DST AUX Port</a>	<a href="#">17</a>
<a href="#">4.4.1. General Guidelines</a>	<a href="#">17</a>
<a href="#">4.4.2. Configuring Seanet Pro</a>	<a href="#">18</a>
<a href="#">4.4.3. Configuring the SeaKing Head</a>	<a href="#">20</a>
<a href="#">4.4.4. Seanet Pro Display</a>	<a href="#">20</a>
<a href="#">4.4.5. Regional Settings and AUX Data</a>	<a href="#">21</a>
<a href="#">4.5. Using with SeaKing 700 Series (Bathy)</a>	<a href="#">22</a>
<a href="#">4.6. AltTest Software</a>	<a href="#">22</a>
<a href="#">4.6.1. General Guidelines</a>	<a href="#">22</a>
<a href="#">4.6.2. Main Functions</a>	<a href="#">23</a>
<a href="#">4.6.3. Options and Log Setup Dialogs</a>	<a href="#">23</a>
<a href="#">4.6.4. Free Running Mode</a>	<a href="#">25</a>
<a href="#">4.6.5. ASCII Interrogate Mode</a>	<a href="#">26</a>
<a href="#">4.6.6. Z Interrogate (Bathymetric Mode)</a>	<a href="#">27</a>
<a href="#">4.6.7. Regional Settings and AltTest</a>	<a href="#">27</a>
<a href="#">5. Maintenance</a>	<a href="#">28</a>
<a href="#">5.1. General Guidelines</a>	<a href="#">28</a>
<a href="#">5.2. Ordering Parts</a>	<a href="#">28</a>
<a href="#">5.3. Disassembly of the Altimeter</a>	<a href="#">29</a>
<a href="#">6. Configuration</a>	<a href="#">30</a>
<a href="#">6.1. Non-configurable Parts</a>	<a href="#">30</a>
<a href="#">6.2. Dip Switch Settings</a>	<a href="#">30</a>
<a href="#">Appendix A. Jumper Settings for SeaKing with Altimeter on AUX Port</a>	<a href="#">32</a>
<a href="#">Glossary</a>	<a href="#">36</a>

## Help & Support

First please read this manual thoroughly (particularly the Troubleshooting section, if present).

*Tritech International Ltd* can be contacted as follows:

	Mail	<i>Tritech International Ltd</i> Peregrine Road Westhill Business Park Westhill, Aberdeenshire AB32 6JL, UK
	Telephone	++44(0)1224 744 111
	Fax	++44(0)1224 741 771
	Email	<a href="mailto:support@tritech.co.uk">support@tritech.co.uk</a>
	Website	<a href="http://www.tritech.co.uk">www.tritech.co.uk</a>

Prior to contacting *Tritech International Ltd* please ensure that the following is available:

1. The Serial Numbers of the product and any *Tritech International Ltd* equipment connected directly or indirectly to it.
2. Software or firmware revision numbers.
3. A clear fault description.
4. Details of any remedial action implemented.



### **Contamination**

If the product has been used in a contaminated or hazardous environment you *must* de-contaminate the product and report any hazards *prior* to returning the unit for repair. *Under no circumstances should a product be returned that is contaminated with radioactive material.*

The name of the organisation which purchased the system is held on record at *Tritech International Ltd* and details of new software or hardware packages will be announced at regular intervals. This manual may not detail every aspect of operation and for the latest revision of the manual please refer to [www.tritech.co.uk](http://www.tritech.co.uk) *Tritech International Ltd* can only undertake to provide software support of systems loaded with the software in accordance with the instructions given in this manual. It is the customer's responsibility to ensure the compatibility of any other package they choose to use.

## Warning Symbols

Throughout this manual the following symbols may be used where applicable to denote any particular hazards or areas which should be given special attention:



### Note

This symbol highlights anything which would be of particular interest to the reader or provides extra information outside of the current topic.



### Important

When this is shown there is potential to cause harm to the device due to static discharge. The components should not be handled without appropriate protection to prevent such a discharge occurring.



### Caution

This highlights areas where extra care is needed to ensure that certain delicate components are not damaged.



### Warning

**DANGER OF INJURY TO SELF OR OTHERS**

Where this symbol is present there is a serious risk of injury or loss of life. Care should be taken to follow the instructions correctly and also conduct a separate Risk Assessment prior to commencing work.

# 1. Specification

## 1.1. Notes on Specifications

The specifications outlined below are for standard altimeters fitted with *Tritech International Ltd* 6-pin connectors and are the most common variant of altimeter supplied by *Tritech International Ltd*. There are a large variety of options available in terms of connectors and it is beyond the scope of this manual to cover every configuration possible.

Other connectors that have been supplied include:

- Burton Seaconn 1508
- Branter SeaCon XSG-4/XSG-5
- Subconn:
  - BH4-F
  - BH6-M
  - BH8-M
  - IL6-FS
  - MCBH4-M SS
  - MCBH5-M
  - MCBH6-F

For each of the above a variety of wiring schemes has been used and so it will be necessary to contact *Tritech International Ltd* for a detailed description of the product supplied (provided serial numbers are available). Additionally, the list is not exhaustive and there may be special items or other connectors that are not included.

**1.2. Dimensions**

**PA200/PA500 Straight Delrin, Aluminium & Stainless Steel**

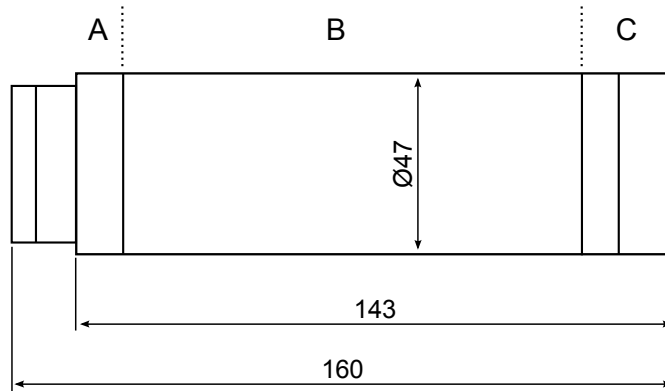

Not to scale, dimensions in mm.



**Note**

The standard *Tritech International Ltd* 6-pin connector is rated to a maximum depth of 4000m, so any deep rated altimeters (up to 6800m) will be fitted with different connectors, the Burton 5506 shown here is a representation only.

**PA200/PA500 Straight Stainless Steel**

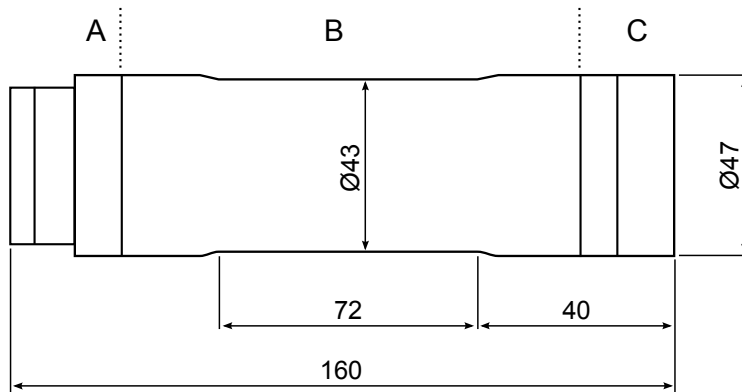

Not to scale, dimensions in mm.

**PA200/PA500 Right Angle Delrin, Aluminium & Stainless Steel**

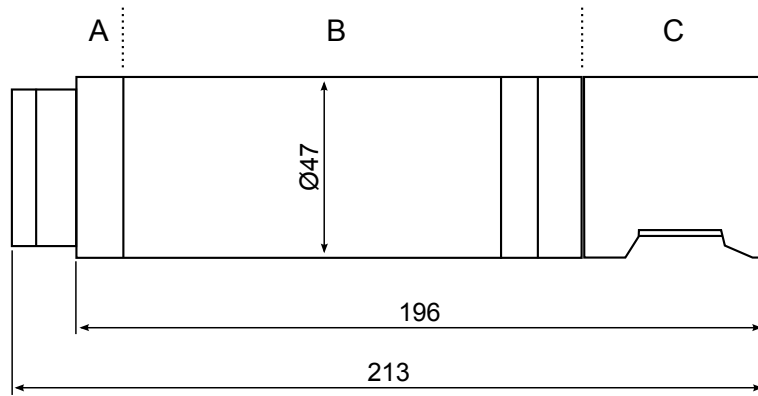

Not to scale, dimensions in mm.



**Note**

The transducer endcap (part C in the image) is made out of ABS regardless of the body material.

The standard *Tritech International Ltd* 6-pin connector is rated to a maximum depth of 4000m, so any deep rated altimeters (up to 6800m) will be fitted with different connectors, the Burton 5506 shown here is a representation only.

**PA200/PA500 Right Angle Stainless Steel**

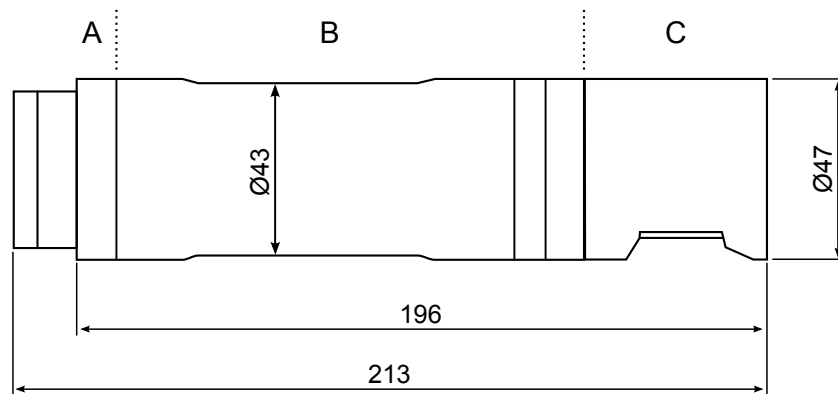

Not to scale, dimensions in mm.



**Note**

The transducer endcap (part C in the image) is made out of ABS regardless of the body material.



### LRPA 4000m

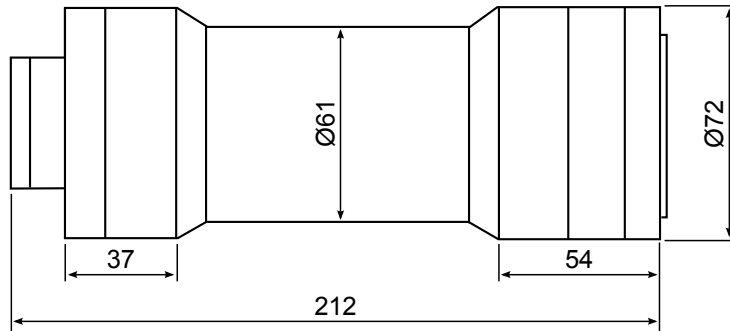

Not to scale, dimensions in mm.

### LRPA 6800m

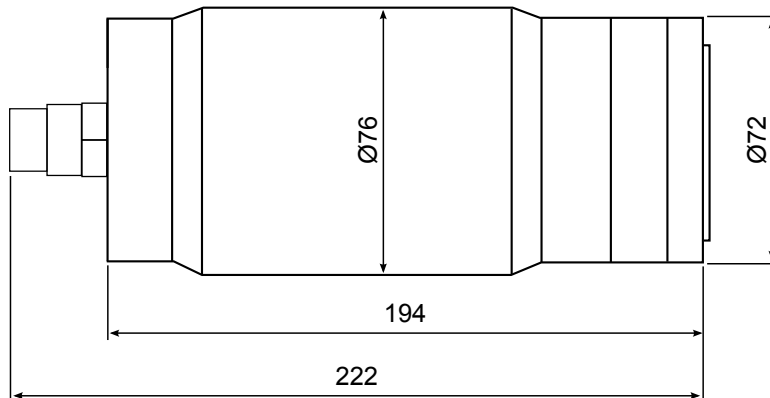

Not to scale, dimensions in mm.



#### Note

The 6800m rated units have a Burton 5506 series connector as standard but other connectors are also used.

### 1.3. PA200/PA500 Electrical and Acoustic

Acoustic	PA200	PA500
Operating frequency	200kHz	500kHz
Beamwidth	12° conical	6° conical
Range	0.7 to 100m	0.3 to 50m (0.1 to 10m optional)
Digital resolution	1mm	
Analogue resolution	0.025% of range	

Electrical and Communication	
Power supply	24V DC at 80mA or 12V DC at 160mA
Analogue output	0 – 10V DC (with 24V power supply), 0 – 5V DC or 4 – 20mA
Data communications	RS232 or RS485
Output modes	Free running, interrogated or part of multidrop network



#### Note

For current loop output of 4-20mA the power supply must be at least 15V DC.

### 1.4. PA200/PA500 Physical and Environmental

Weights	1.15kg in air, 0.8kg in water (stainless steel body)
Depth rating	700m with Delrin housing (aluminium alloy endcap) 4000m with aluminium alloy housing 4000/6800m with stainless steel housing 6800 with titanium 6Al-4V housing
Materials	Dependent on depth, as shown above for straight transducer models All right-angle transducers are ABS (part C in the diagrams)
Operating temperature	-10 to 35°C
Storage temperature	-20 to 50°C

**1.5. LRPA Electrical and Acoustic**

<b>Acoustic</b>	
Operating frequency	200kHz
Beamwidth	10° conical
Range	2 to 200m
Digital timing resolution	1mm
Analogue resolution	0.025%

<b>Electrical and Communication</b>	
Power supply	24V DC at 90mA (12V DC optional)
Analogue output	0 to 20V DC (with 24V power supply) 0 to 5V DC 4 to 20mA
Data communications	RS232 to RS485
Output modes	Free running, interrogated or part of multidrop network

**1.6. LRPA Physical and Environmental**

	<b>Standard model</b>	<b>Deep rated model</b>
Weight in air	1.3kg	4.33kg
Weight in water	0.95kg	2.93kg
Depth rating	4000m	6800m
Operating temperature	-10 to 35°C	
Storage temperature	-20 to 50°	

## 2. Introduction

The PA200, PA500 and LRPA are sonar ranging devices which when mounted vertically give the height above the sea bed or in any other orientation provides a method for measuring subsea distances. The altimeters can be configured to operate on their own or under control from an external unit.

The altimeters incorporate a fixed crystal transducer which is matched to the range and resolution required. The altimeter data output signals can be transmitted as both digital and analogue signals and can communicate using RS232 or RS485 protocols.

This manual covers the generic aspects of altimeters and shows the specifications for the standard setup with the *Tritech International Ltd* 6 pin connector. There are a vast amount of different configurations available for Tritech altimeters so it is important to use this manual in conjunction with the original purchase order which should detail the exact configuration of the product in hand.

If the details from the original order are not available please try contacting *Tritech International Ltd* to retrieve the information. It will be necessary to supply all the serial numbers off the altimeter body and/or label.

## 3. Installation

### 3.1. Optimal Orientation

For ROV installation always mount the altimeter so that it is as close to the true vertical as possible in relation to the trim position of the vehicle. The transducer head should be clear of any obstruction and away from possible sources of interference, such as the wake from thrusters or from electrical devices that may have high electromagnetic emissions. Errors in the head alignment can give rise to unreliable results.

### 3.2. Mounting Material and Suitable Brackets



#### Caution

Avoid any metal alloys containing copper such as brass or bronze.

Non-metallic clamps should always be used where possible to prolong the life of the unit and prevent any galvanic corrosion effects. If metallic clamps are used they should be electrically insulated from the sonar body by means of rubber or plastic strips or mount brackets of at least 3mm thickness and extending at least 3mm beyond the clamp boundary. They should also be painted or lacquered with at least three coatings.

### 3.3. Long Term Use



#### Caution

The stainless steel altimeters are not designed for long-term submersion and may suffer from corrosion if left underwater or in a splash zone for extended periods. Refer to the maintenance section for appropriate care.

### 3.4. Standard Pin-Out Diagrams



#### Caution

The power should be turned off before making a connectino between the sonar head and surface controller (SCU or SeaHub).

The altimeter can operate in RS232 serial mode, RS485 serial mode, in analogue mode and as a current loop device. Analogue and serial modes can run on the same device with the analogue output signal on Pin 5. The pin out configurations are shown below for each type. Note that the different types require different communications boards so it is not generally possible to change from one type to another without returning the unit to Trittech.

### RS232 Configuration

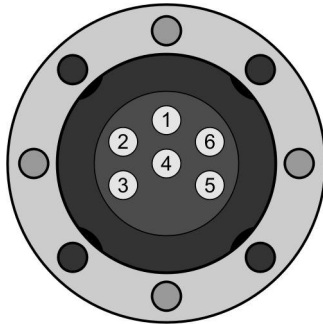

*Trittech Waterblock*

Pin	Function	Wire Colour
1	RS232 TX	Yellow
2	RS232 RX	Blue
3	+V DC	Red
4	0V, RS232 Ground Analogue Ground	Black
5	Analogue Output (optional)	Green
6	Chassis Ground	cable screen

### RS485 Configuration

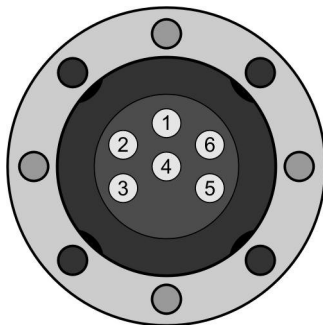

*Trittech Waterblock*

Pin	Function	Wire Colour
1	RS485 A	Yellow
2	RS485 B	Blue
3	+V DC	Red
4	0V, Analogue Ground	Black
5	Analogue Output (optional)	Green
6	Chassis Ground	cable screen

### Current Loop Configuration

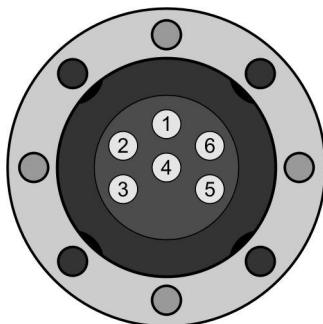

*Trittech Waterblock*

Pin	Function	Wire Colour
1	+ Current Loop	Yellow
2	- Current Loop	Blue
3	+V DC	Red
4	0V, Analogue Ground	Black
5	Analogue Output (optional)	Green
6	Chassis Ground	cable screen

**Analogue Only Configuration**

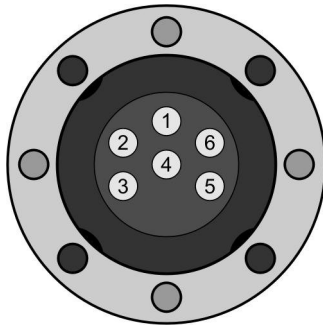

*Tritech Waterblock*

Pin	Function	Wire Colour
1	(not used)	Yellow
2	(not used)	Blue
3	+V DC	Red
4	0V, Analogue Ground	Black
5	Analogue Output	Green
6	Chassis Ground	cable screen

## 4. Operation

### 4.1. General Guidelines

The output from the altimeter can be in serial or analogue format. This section only covers applications which use the data in serial format.

The transducers of altimeters configured with a 10m range may ring when operated in air resulting in false readings being given (neither Zero nor Maximum Value). This ringing will not occur when the unit is operated under water.

### 4.2. Output Strings

The serial output is either interrogated (i.e., the software asks for a response) or is free-running and will continuously send out acoustic pulses and supply the output from the altimeter to the connected computer even if the software is not running. The output is an ASCII data string terminated with a carriage return and line feed (<CR><LF>) and will be in one of three formats depending on the hardware settings.

These formats are as follows:

2P3 `XX.XXXm<CR><LF>`

3P3 `XXX.XXXm<CR><LF>`

3P2 `XXX.XXm<CR><LF>`

In free running mode the unit will start to output data immediately upon power up (the data rate is about 10Hz for a PA500 or 7Hz for a PA200). If the altimeter has been set to interrogate mode it will not output data until the interrogate command (Z) is received, at which point a single data string is transmitted to the surface computer.



#### In RS232 Mode

When operating an RS232 altimeter it is possible to change the mode of operation from free running to interrogate and back. Sending an F character will change the unit to operate in free running mode and sending a Z character will change it to operate in interrogate mode.



#### In RS485 Mode

For RS485 units the mode should not be changed via serial commands. The RS485 protocol used is a 2 wire half duplex and this means that the unit never enters the 'listen' mode when set to free running so attempting to change the unit with a serial command may result in unforeseeable results or loss of communication with the device.



To confirm which mode the altimeter is in a simple test is to power on the unit and listen for any audible clicks or pings. In free running mode the altimeter will start pinging as soon as it receives power but in interrogated mode it should remain silent.



### **Warning**

NEVER place the transducer close to the ear to listen for the clicks. Doing so could result in permanent damage to the eardrum. Always remain at least 15cm away from the transducer.

## ***4.3. Data Stream Characteristics***

The default altimeter output communication characteristics are as follows:

- 9600 baud
- 8 data bits
- 1 stop bit
- No parity
- No flow control

Depending on the dip switch settings the unit will either output a 0 result or the maximum possible result whenever a valid signal is not detected (i.e., fail low or fail high). These settings are, respectively, Zero No Echo (ZNE) or Max No Echo (MNE). These settings are fully hardware controlled and cannot be over-ridden in software.

## ***4.4. Seanet Pro and SeaKing or Super SeaPrince DST AUX Port***

### **4.4.1. General Guidelines**

It is possible to configure the AUX port on a SeaKing or Super SeaPrince DST sonar for input of RS232 or RS485 serial data from a free running altimeter. The altimeter is connected via a dual 6-pin Tritech interconnect cable which has a one-to-one wiring between the pins. The DC power input of the sonar is linked through to the AUX port for the 24V DC supply to the altimeter.



### **Caution**

The supply to the SeaKing head SHOULD NOT exceed 28V DC, doing so will damage the altimeter connected to the AUX port.



**Caution**

If using an altimeter with the RS232 board fitted it will be necessary to modify the SeaKing head to enable communication. Details for this procedure can be found in *Appendix A. Jumper Settings for SeaKing with Altimeter on AUX Port* For this reason it is recommended that an altimeter is chosen with the RS485 board fitted because this avoids breaking the power isolation in the SeaKing head and also allows the altimeter analogue output to be passed through the sonar head (via a jumper setting within the SeaKing and on Pin 5).



**Note**

The altimeter will have to be in a compatible free running mode in order to work. If it is set up for interrogated mode the switch settings will have to be changed within the unit, refer to *see 6. Configuration* for more details of the correct dip switch settings and supported modes.

**4.4.2. Configuring Seanet Pro**

First launch the Seanet Setup application and ensure that Node 2 is detected in the table, indicating that the SeaKing sonar head is visible to the computer. Click the Action column for Node 2 and then select Setup.

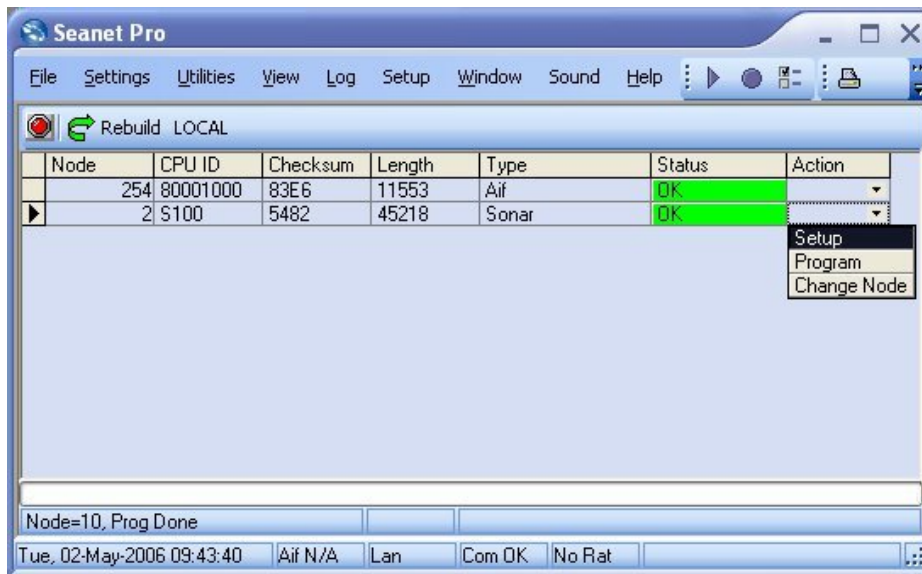

In the sonar setup dialog which is presented, ensure that the Has Aux or Compass check box is enabled.

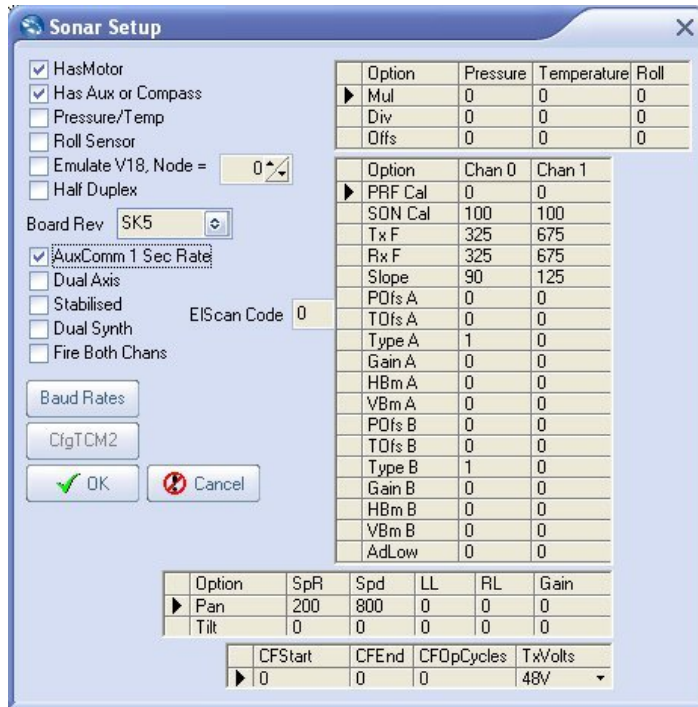

**Note**

If the sonar is a V6 DST Super SeaKing or Super SeaPrince DST then the AUX port is enabled continuously. A V6 can be identified by having a different setup screen as shown below. For the Super SeaPrince DST the Comms Mode selection is used to control the AUX port as well as the MAIN port so the protocol and baud rates for the AUX port will need to be set correctly.

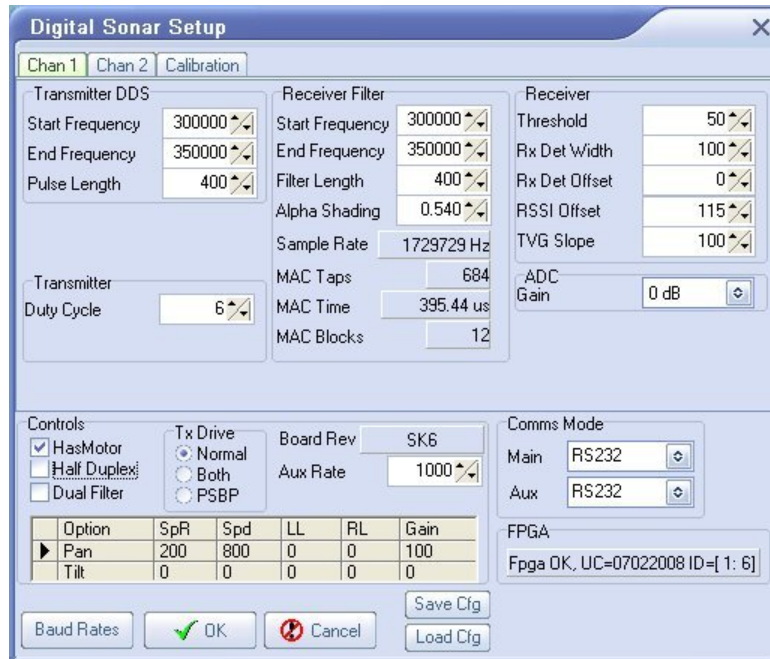



**Note**

If the AuxComm 1 Sec Rate check box is disabled, the sonar will try to send all of its data collected through the auxiliary port in one go and if the quantity and rate of this data is too great then the interface may hang.

From the above dialog click on the Baud rates button and check that the rates on the Async 1 (AUX) match the device output (this is normally 9600 baud for altimeters).

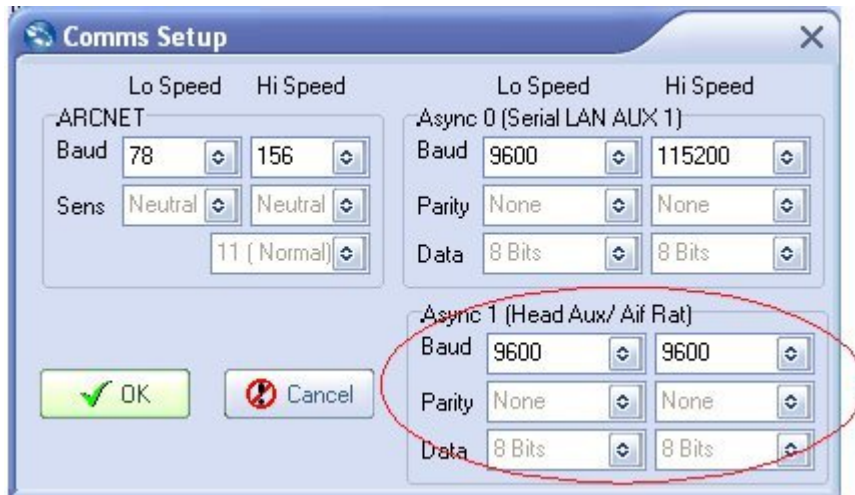

**4.4.3. Configuring the SeaKing Head**

After the software has been configured the SeaKing head should be modified to allow correct communication.

For the correct jumper settings refer to *Appendix A. Jumper Settings for SeaKing with Altimeter on AUX Port*



**Important**

In order to change the jumper settings it will be necessary to expose sensitive electronics within the SeaKing head and so appropriate measures should be taken to protect against

**4.4.4. Seanet Pro Display**

Once the sonar head has been correctly configured with the altimeter connected, power up the system and run the main Seanet Pro application. Test the operation of the system by running a Sonar Application which should display similar to the screenshot below. Note that the altimeter data received via the sonar AUX port is displayed as a reading in metres on the Sonar Settings Bar.



**Note**

The altimeter data will be logged along with the sonar data and will be displayed during playback of the log file.

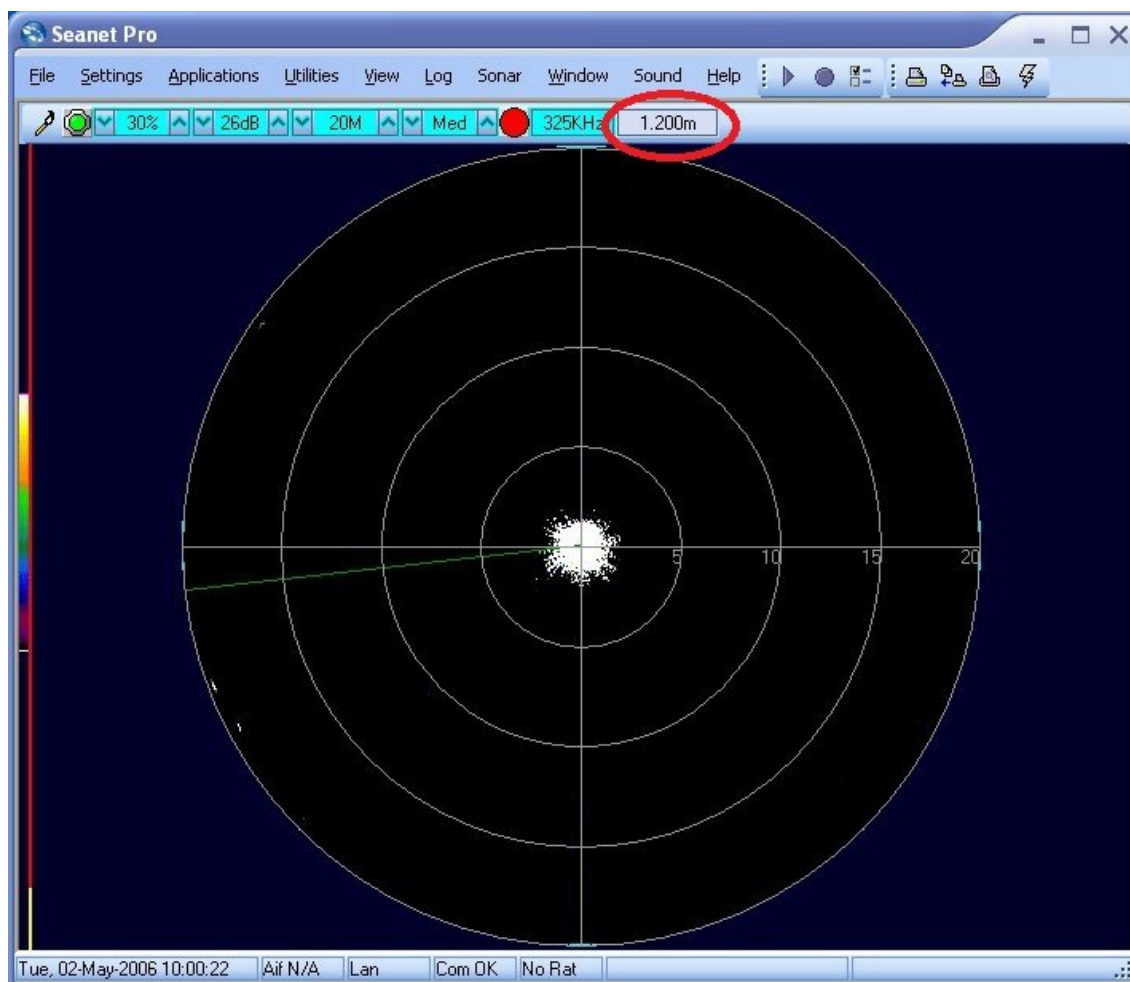

**4.4.5. Regional Settings and AUX Data**

Under certain versions of Windows the regional settings can prevent the flow of data from an AUX port through the system. If the device has been connected correctly and is operating properly but no data is displayed on the screen then the regional settings may be preventing Seanet Pro from processing the data.

This problem can be overcome using two methods:

1. From the Windows Control Panel open Regional & Language Options and set the drop down list to English (United Kingdom) and press OK for the changes to take effect. It will be necessary to restart the Seanet Pro application after this change has been made.
2. If it is desired to continue using the existing regional settings then from the Regional & Language Options dialog find the existing language settings and choose Customise. Locate the setting for Decimal Symbol and make sure it is set to ".".

### 4.5. Using with SeaKing 700 Series (Bathy)

Usually if using an altimeter with a SeaKing 700 Series device it is merely a case of connecting the altimeter supplied as part of the system to the AUX port. If another altimeter is to be used it will have to be configured using the dip switches (*see 6. Configuration*) to work correctly.

A comprehensive description of the correct setup for the SeaKing 700 Series can be found in the SeaKing 700 Series Product Manual.

### 4.6. AltTest Software

#### 4.6.1. General Guidelines

The AltTest program available from Trittech provides a simple way of communication with Trittech altimeters and displaying the data. It is compatible with Microsoft Windows. Altimeter data can be logged in a raw or processed format and the processed data can be imported into a spreadsheet package for post-processing.



**Note**

AltTest is freely available from [www.tritech.co.uk](http://www.tritech.co.uk).

The main display for the AltTest program is as follows:

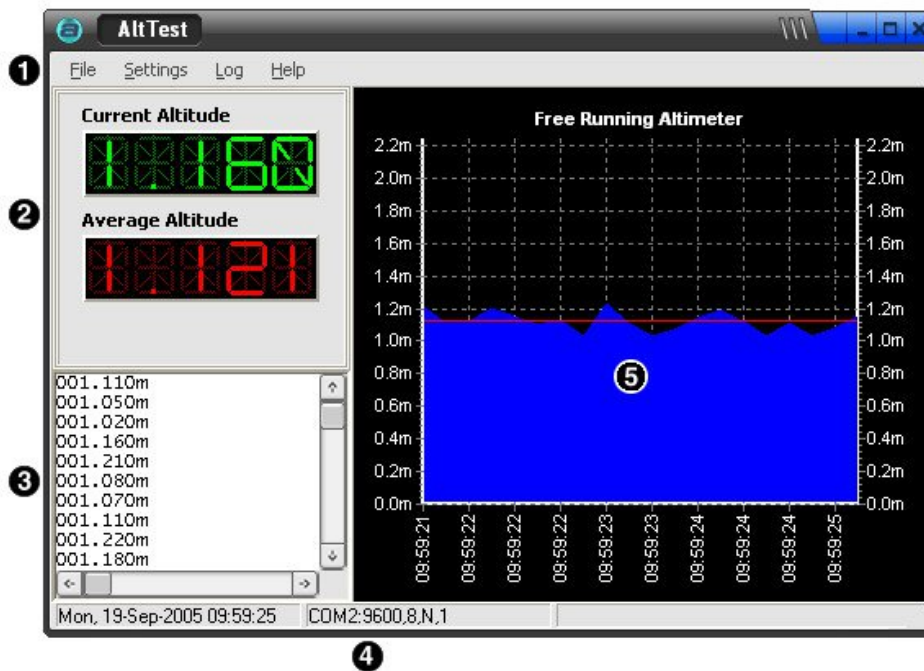

- ❶ Menu Options
- ❷ Current and average altitude display.  
The display will change depending on the operating mode
- ❸ Terminal style window displaying the raw data received from the altimeter
- ❹ Serial port settings
- ❺ Scrolling altitude chart.  
Displays current altitude in solid blue and average altitude as a red line

#### 4.6.2. Main Functions

- File
  - Exit closes the AltTest application.
- Settings
  - COM port to change the settings of the COM port.
  - Options to change the application options (see below).
- Log
  - Format selecting a Raw format will log the exact data string that is sent by the altimeter while Processed will log all the processed data and settings in Comma Separated Value (CSV) format.
  - Setup sets the logging options (see below).
  - Record toggle to start/stop logging the data.
- Help
  - About details the AltTest application, while System shows information about the Windows system.

#### 4.6.3. Options and Log Setup Dialogs

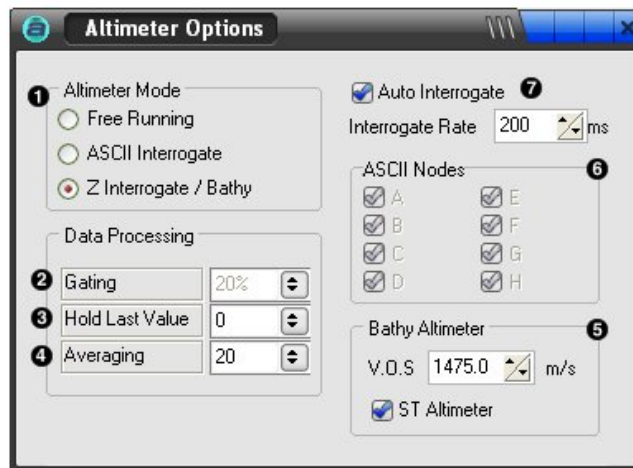

- ❶ Altimeter Mode sets the operating mode (see descriptions below).
- ❷ Gating to select the percentage to user for the gating range of an altitude reading. The gating range is calculated as  $\pm$  the gating of the last altitude reading (i.e., for gate set at

20% the gating range is  $\pm 20\%$  of the last altitude reading). If the next altitude reading falls out of the range then it is regarded as invalid and the previous altitude reading is used.

- ③ Hold Last Value for selecting how long the program will hold onto the last valid altitude reading. If an altitude reading falls out of the gating range of the previous reading then it will be held for a specified number of readings or until a reading within the gating range is received. If this is set to "0" then AltTest ignores gating ranges and regards all altitude readings as valid.
- ④ Averaging for selecting how many data samples to use when calculating the average altitude of an altimeter.
- ⑤ Bathymetric Options for entering the velocity of sound when AltTest is used with a Bathymetric altimeter. Also allows the selection of older "ST" model altimeters.
- ⑥ ASCII Nodes for selecting the ASCII Addressed Nodes to be interrogated. Only available in ASCII Interrogate Mode
- ⑦ Auto Interrogate set to automatically interrogate the altimeter by the interval set. Only available in ASCII Interrogate or Z Interrogate modes.

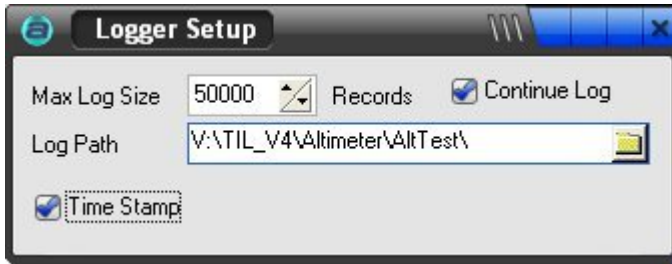

- Max Log Size      Set the maximum number of records a log file can hold.
- Log Path            Set the path to store the log files.
- Time Stamp        Check to time stamp each line of log data.
- Continue Log        Check to continue logging to a new file once the maximum number of log records has been reached.



#### 4.6.4. Free Running Mode

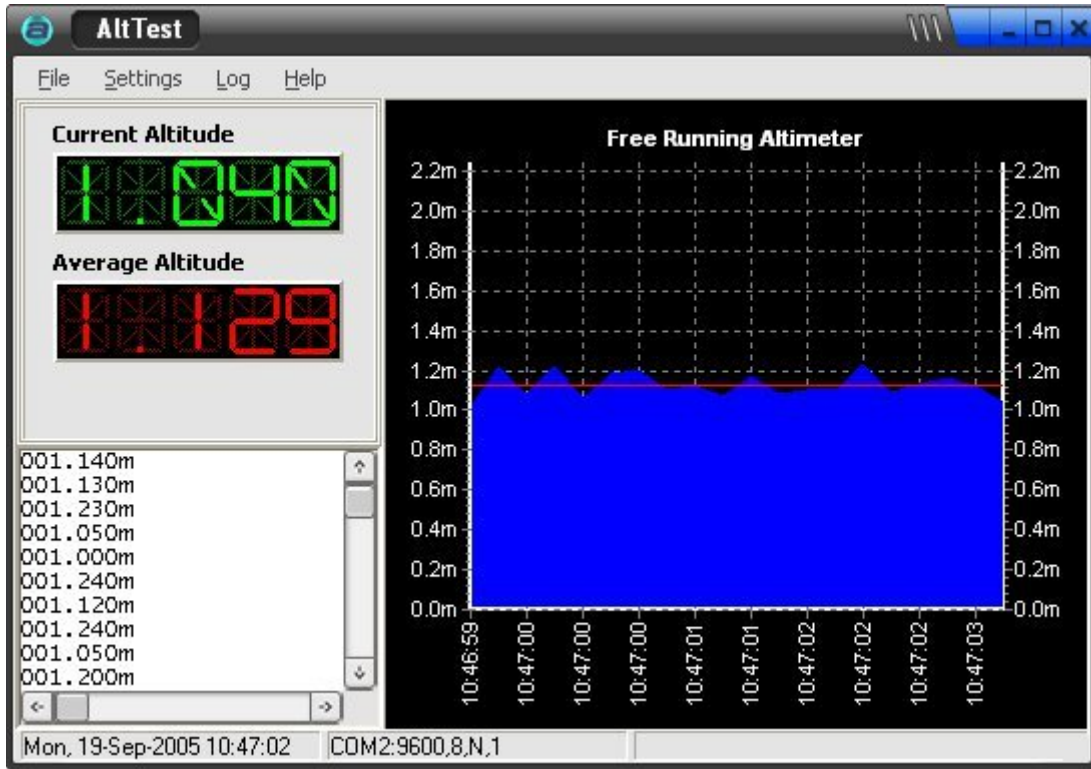

Select Free Running Mode for an altimeter which has been configured to operate as a free running altimeter. The altimeter mode is set by dip switches (*see 6. Configuration*). When in free running mode, the altimeter is operating under its own control sending out data and it requires no interrogation from the AltTest program.

AltTest displays the current altitude of the altimeter and plots it on the chart. AltTest will also calculate an average altitude using the specified number of data samples set from the Options dialog and this is also displayed on the chart. The number of data samples displayed on the chart will be the same number used to calculate the average altitude.

### 4.6.5. ASCII Interrogate Mode

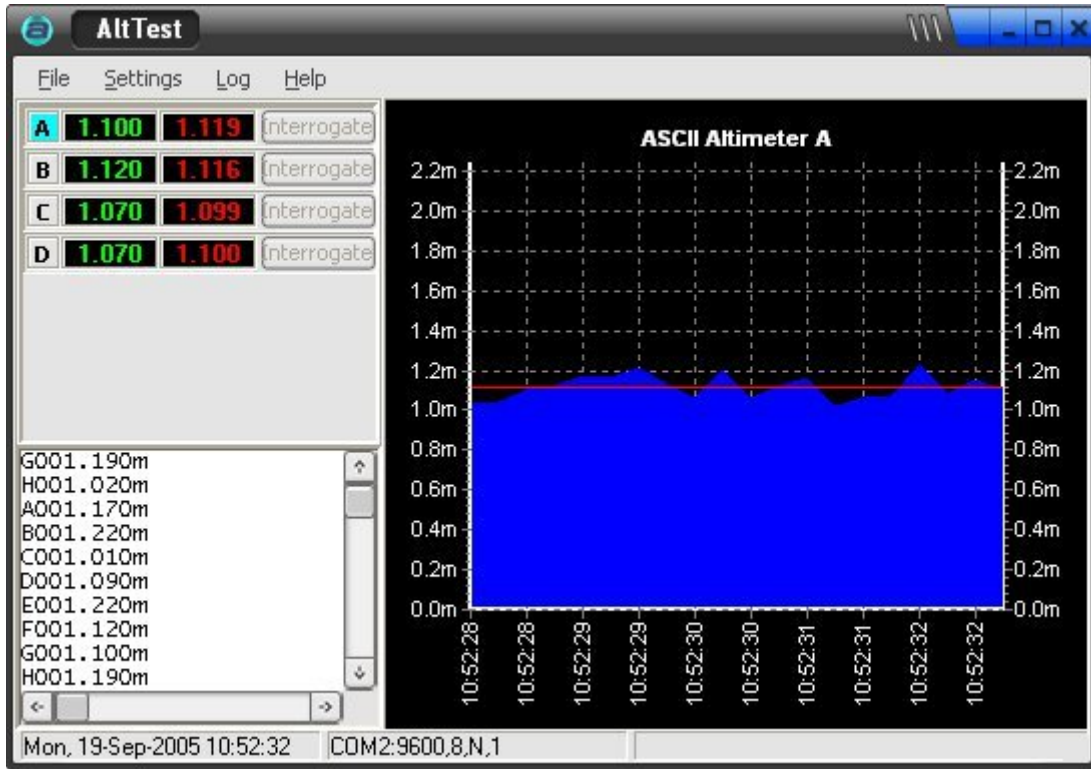

Select ASCII Interrogate Mode for altimeters configured as ASCII addressable nodes (single character ASCII address in the range A to H). The address is set by switch settings inside the altimeter (see Chapter 6, Configuration) and are always triggered by interrogation (they cannot free run).

ASCII addressable units may be connected together on an RS485 or multidrop RS232 communications link.

AltTest allows the user to select which addressable units are available for interrogation. Nodes that have been selected are on the display. Each node can be manually interrogated by pressing its Interrogate button. All available nodes can also be automatically interrogated using the Auto Interrogate function at the rate defined from the Options dialog.

AltTest displays the current altitude of the altimeter. It also calculates an average altitude using a specified number of data samples which is also displayed. The altimeter data displayed on the chart can be selected by clicking on an altimeter's address panel which will then be highlighted. The number of data samples plotted on the chart will be the same number used to calculate the average altitude.

#### 4.6.6. Z Interrogate (Bathymetric Mode)

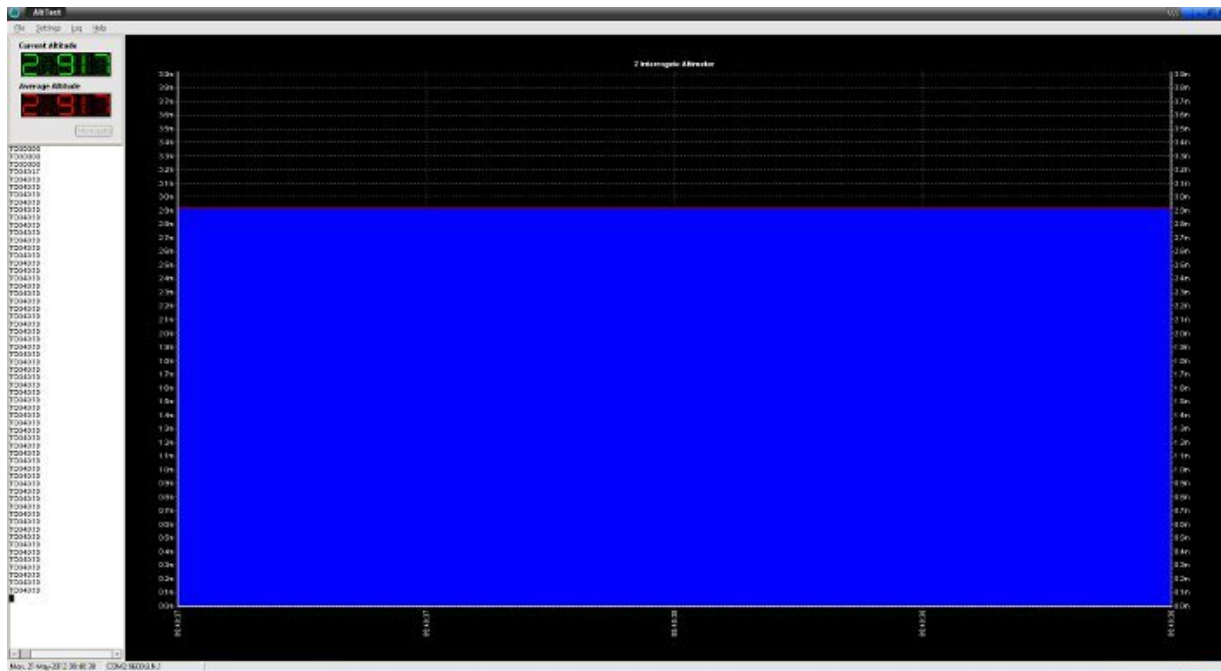

Select Z Interrogate mode for an altimeter configured to be interrogated by the character "Z" or for an altimeter configured to be used as part of a SeaKing Bathymetric system.

AltTest allows the user to manually interrogate the altimeter by pressing the Interrogate button. The altimeter can also be automatically interrogated using the Auto Interrogate function at the rate defined by the settings in the Option dialog.

AltTest displays the current altitude of the altimeter and plots it on the chart. AltTest will also calculate an average altitude using a specified number of data samples which is also displayed and charted. The number of data samples plotted on the chart will be the same number used to calculate the average altitude.

#### 4.6.7. Regional Settings and AltTest

Under certain versions of Windows the regional settings can prevent the flow of data from the serial port to AltTest. If the device has been connected correctly and is operating properly but no data is displayed on the screen then the regional settings may be preventing AltTest from processing the data.

This problem can be overcome using two methods:

1. From the Windows Control Panel open Regional & Language Options and set the drop down list to English (United Kingdom) and press OK for the changes to take effect. It will be necessary to restart the Seanet Pro application after this change has been made.
2. If it is desired to continue using the existing regional settings then from the Regional & Language Options dialog find the existing language settings and choose Customise. Locate the setting for Decimal Symbol and make sure it is set to "."

## 5. Maintenance

### 5.1. General Guidelines



#### Note

Every time the altimeter is retrieved from the water it should be washed with a mild soap solution to clear any marine growth and inspected for signs of damage.

The standard altimeter has three user serviceable items:

- The o-ring on the transducer endcap.
- The o-ring on the connector endcap.
- The o-ring present underneath the waterblock.



#### Note

Alternative configurations may have additional serviceable items, if in doubt please contact *Tritech International Ltd* to establish the correct service routine.

The o-ring seals should be regularly inspected, cleaned and lubricated with the appropriate greasing compound. The body of the unit should also be inspected for any obvious signs of corrosion, especially in mating surfaces (such as the waterblock).



#### Caution

It is essential to have a regular maintenance schedule so that any defects arising from corrosion or erosion can be spotted early and corrected before they cause severe damage to the unit.



#### Caution

Care should be taken when inspecting the altimeter with a Delrin housing material due to the internal copper earth shield. This shield can be easily damaged by the PCB during disassembly and subsequent re-assembly.

### 5.2. Ordering Parts

For replacement parts or spare parts it will be necessary to correctly identify the altimeter in

use. Since there are a vast amount of different configurations of altimeters the simplest way to do this is to contact Tritech International Ltd providing the serial numbers off the unit body.

Serial numbers are either located on the silver label affixed to the body tube or if this has been damaged the embossed numbers on the transducer endcap, body tube and connector endcap can be used instead.

### 5.3. *Disassembly of the Altimeter*



#### **Important**

The steps outlined here will expose sensitive electronic equipment and so appropriate steps should be taken to prevent any static discharge occurring which may harm the equipment.

#### **Service tools required**

- Clean absorbent wipes
- Silicon grease MS-111 lubricant (or equivalent)

#### **Disassembly**

1. First rinse the altimeter and connector in fresh water and dry with absorbent wipes.
2. Grasp the connector endcap firmly in one hand and the body tube in the other.
3. Gently unscrew the body tube.
4. The electronics block will then slide out of the housing attached to the endcap.
5. The transducer may be unscrewed from the opposite end of the body tube in the same way.

#### **Re-assembly**

1. Carefully clean all parts and check for damage.
2. Inspect o-ring seals and replace if necessary.
3. Check that the earth loop on the electronics block is secure and sprung so that it will contact the inside face of the body tube when it is fitted.
4. Lightly grease the o-rings, o-ring grooves and mating surfaces.
5. First screw on the transducer to the body tube.
6. Carefully insert the electronics block into the body tube and screw on the endcap.
7. Ensure that the individual parts are aligned and mating correctly.

## 6. Configuration

### 6.1. Non-configurable Parts

Normally when an altimeter is ordered from *Tritech International Ltd* a configuration sheet is filled out with the customer to specify the function of the device exactly. Some of these configurations are controlled through dip switches (detailed below), however, the following list of parts are determined by a particular hardware configuration.



#### Note

It is possible to replace or alter some of these components, however, doing so would normally require the altimeter to be returned to *Tritech International Ltd* for a re-build. Contact details are at the start of this manual if such a change is desired.

The following aspects are usually fixed at manufacture for the life of the product:

Physical hardware	Casing, connector type and wiring scheme.
Analogue Voltage Control	Fixed at: none, 5V or 10V – altering this would require a new electronics block.
Serial/Current output	Fixed at: 4-20mA, RS232 or RS485 – altering this would require a new communications board.
Ping rate	The default ping rate for free-running mode is approximately 10Hz for a PA500 and 7Hz for a PA200 (other ping rates are available).
Velocity of Sound	Set to either 1470m·s <sup>-1</sup> or 1473m·s <sup>-1</sup>

### 6.2. Dip Switch Settings



#### Note

The switch positions shown here are the generic settings which apply to all altimeters. There are other combinations which relate to specific customer's requirements and these are not shown. If in doubt contact *Tritech International Ltd* prior to making any changes.

SW1 Dip Switches Input/Output

SW1 Dip Switches							Input/Output			
ID	1	2	3	4	5	6	String Output Format	Output Behaviour	Output if no echo received	Interrogate Character
4	0	0	1	0	0	0	000.000m	Interrogated	Zero	Z
5	1	0	1	0	0	0	000.000m	FreeRunning	Zero	n/a
6	0	1	1	0	0	0	000.000m	Interrogated	Maximum	Z
7	1	1	1	0	0	0	000.000m	FreeRunning	Maximum	n/a
8	0	0	0	1	0	0	00.000m	Interrogated	Zero	Z
9	1	0	0	1	0	0	00.000m	FreeRunning	Zero	n/a
10	0	1	0	1	0	0	00.000m	Interrogated	Maximum	Z
11	1	1	0	1	0	0	00.000m	FreeRunning	Maximum	n/a
12	0	0	1	1	0	0	000.00m	Interrogated	Zero	Z
13	1	0	1	1	0	0	000.00m	FreeRunning	Zero	n/a
14	0	1	1	1	0	0	000.00m	Interrogated	Maximum	Z
15	1	1	1	1	0	0	000.00m	FreeRunning	Maximum	n/a
16	0	0	0	0	1	0	Bathymetric	Interrogated	Zero	Z
17	1	0	0	0	1	0	NMEA	FreeRunning	Zero	n/a
18	0	1	0	0	1	0	NMEA	FreeRunning	Maximum	n/a
32	0	0	0	0	0	1	A000.000m	Interrogated	Zero	A
33	1	0	0	0	0	1	B000.000m	Interrogated	Zero	B
34	0	1	0	0	0	1	C000.000m	Interrogated	Zero	C
35	1	1	0	0	0	1	D000.000m	Interrogated	Zero	D
36	0	0	1	0	0	1	E000.000m	Interrogated	Zero	E
37	1	0	1	0	0	1	F000.000m	Interrogated	Zero	F
38	0	1	1	0	0	1	G000.000m	Interrogated	Zero	G
39	1	1	1	0	0	1	H000.000m	Interrogated	Zero	H
40	0	0	0	1	0	1	A000.000m	Interrogated	Maximum	A
41	1	0	0	1	0	1	B000.000m	Interrogated	Maximum	B
42	0	1	0	1	0	1	C000.000m	Interrogated	Maximum	C
43	1	1	0	1	0	1	D000.000m	Interrogated	Maximum	D
44	0	0	1	1	0	1	E000.000m	Interrogated	Maximum	E
45	1	0	1	1	0	1	F000.000m	Interrogated	Maximum	F
46	0	1	1	1	0	1	G000.000m	Interrogated	Maximum	G
47	1	1	1	1	0	1	H000.000m	Interrogated	Maximum	H

SW2 Dip Switch			
2	3	4	Analogue Scaling
1	1	1	2m
0	1	1	5m
1	0	1	10m
0	0	1	15m
1	1	0	20m
0	1	0	30m
1	0	0	50m
0	0	0	100m



**Note**

On SW1 settings with ID0 to ID3 are for factory use only. ID19 to ID31 and greater than ID47 relate to application specific configurations. If the altimeter has a switch setting that is not listed, please contact Trittech prior to making any changes.



**Note**

On SW2 dip switch 1, 5 and 6 are for factory use only and should not be changed.

## Appendix A. Jumper Settings for SeaKing with Altimeter on AUX Port



### Note

If the sonar is fitted with a COMV6 PCB it will not be possible to change the settings using jumper switches and instead the settings should be changed through software using the Seanet Setup program.

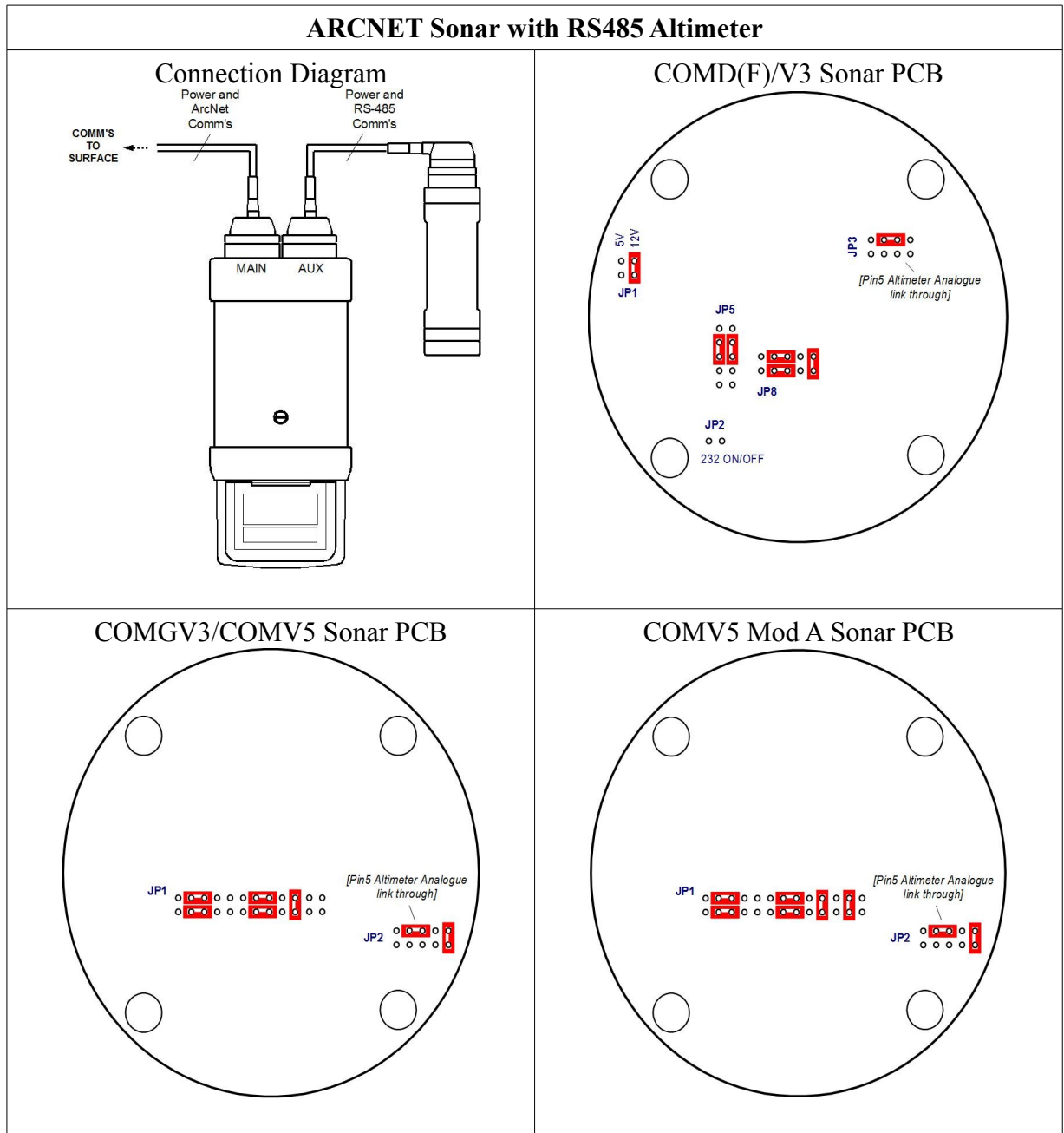



**RS232 Sonar with RS485 Altimeter**

**Connection Diagram**

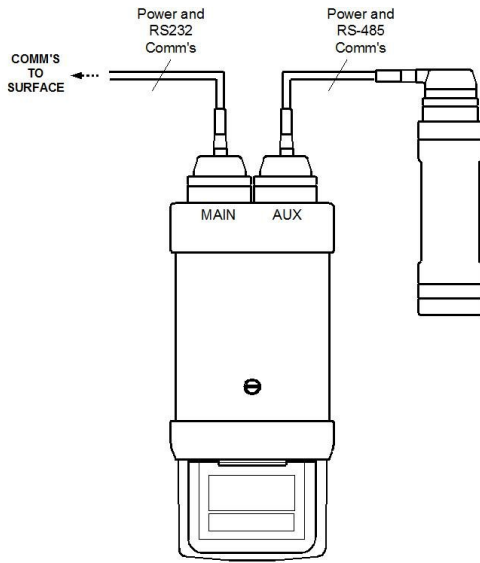

**COMD(F)/V3 Sonar PCB**

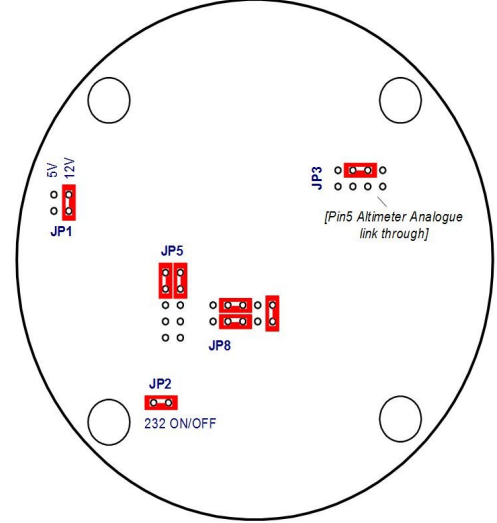

**COMGV3/COMV5 Sonar PCB**

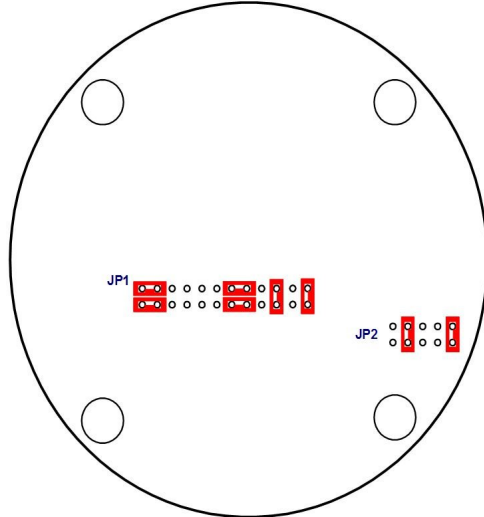

**COMV5 Mod A Sonar PCB**

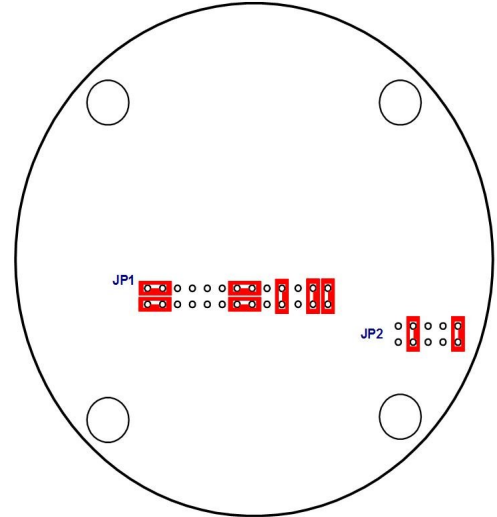

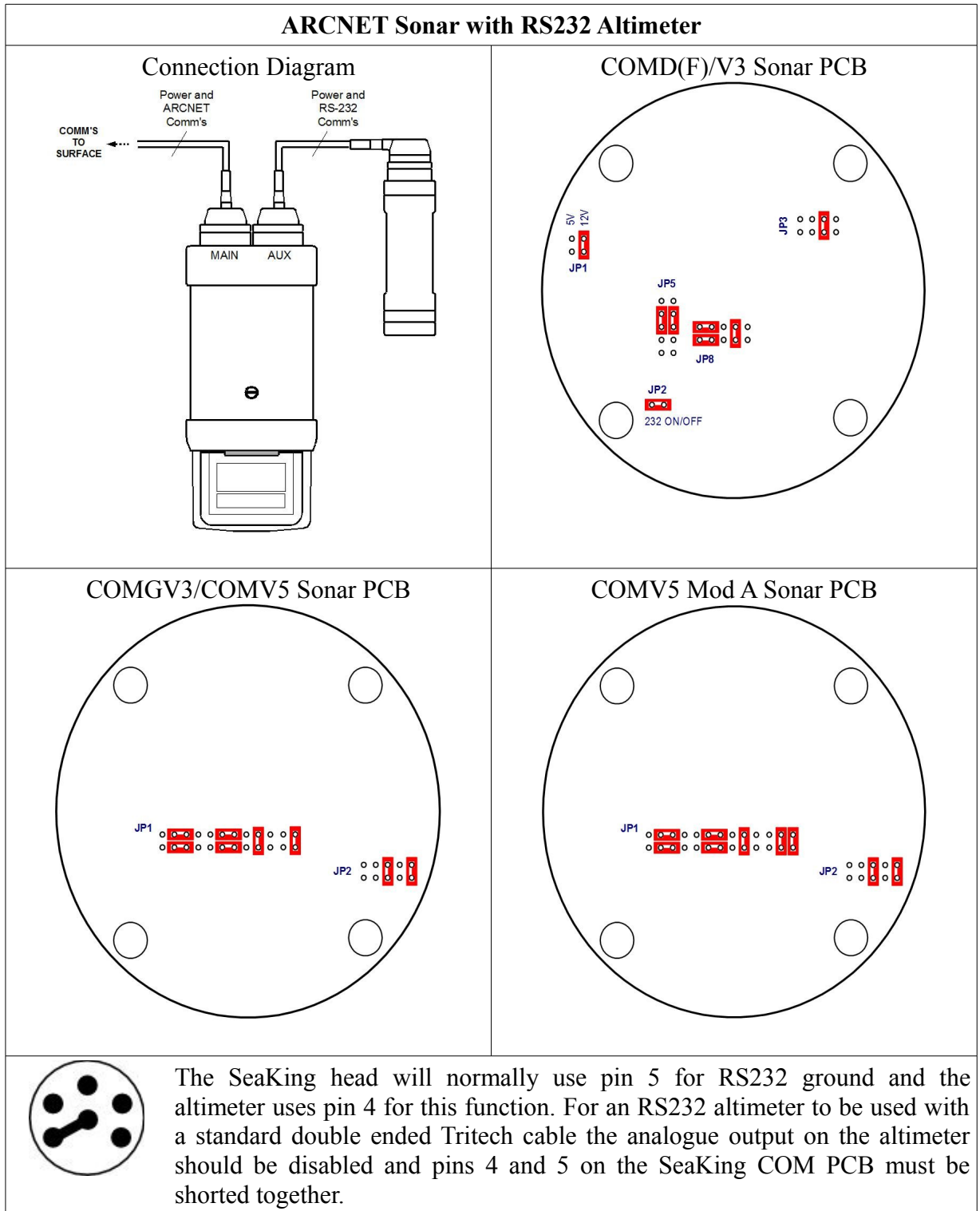

**RS232 Sonar with RS232 Altimeter**

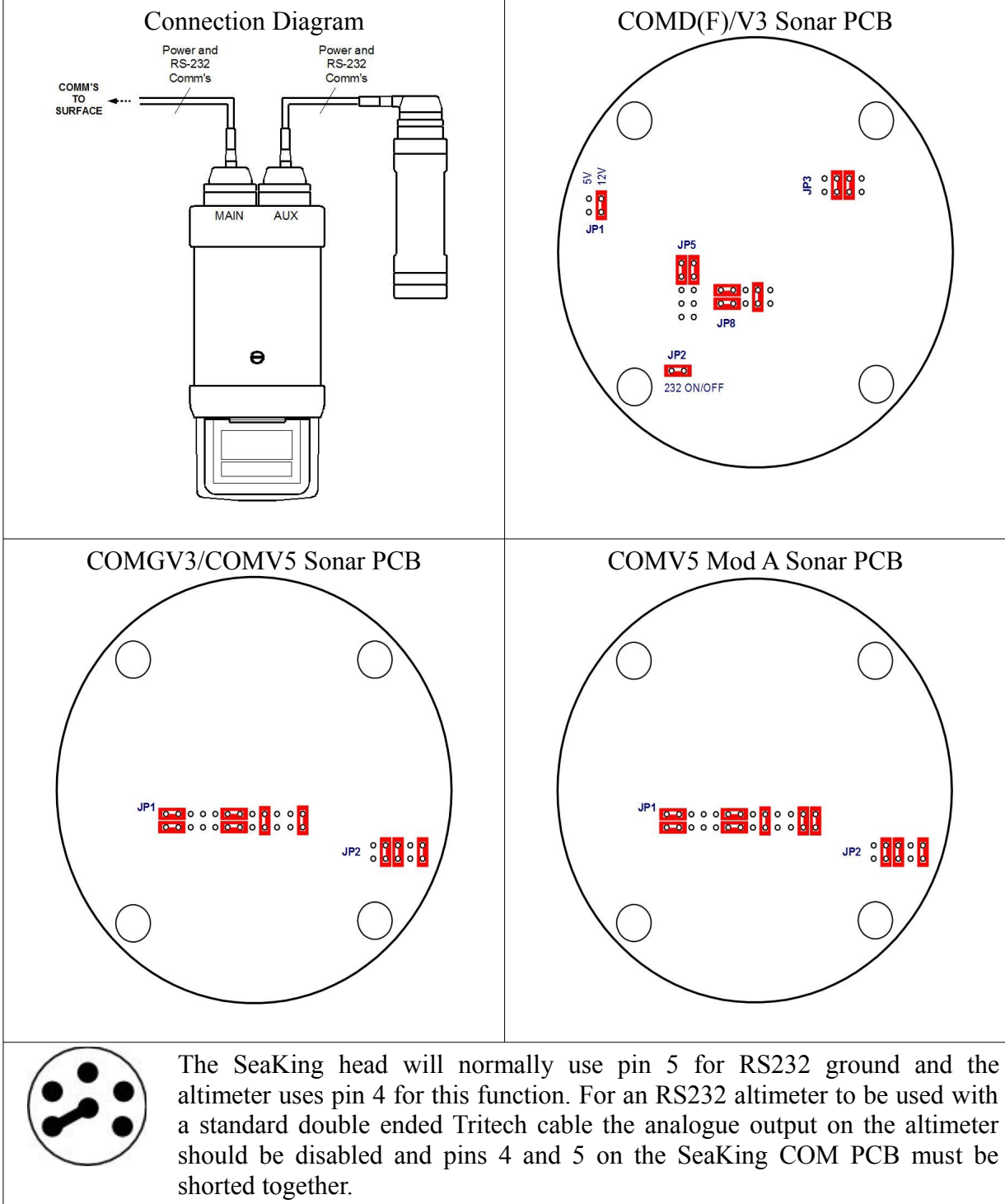

## Glossary

ABS	Acrylonitrile Butadiene Styrene – a common thermoplastic.
ARCNET	Attached Resource Computer NETWORK – a network protocol similar to Ethernet but with the advantage of working over much longer ranges.
ASCII	American Standard Code for Information Interchange – a character encoding scheme originally based on the English alphabet.
Bathy	Alternate name for the Trittech International Ltd SeaKing 700 Series Integrated Oceanographic Sensor Suite which outputs data about the conditions of the seawater and water column which may have an affect on the sonar (temperature, depth, etc.,)
CSV	Comma Separated Value – a text file in tabular format with table cells separated by commas, usually given the filename extension .csv but this can vary depending on the application.
DC	Direct Current
DST	Digital Sonar Technology
PA500	An altimeter sold by Trittech International Ltd
PCB	Printed Circuit Board
ROV	Remotely Operated Vehicle
RS232	Traditional name for a series of standards for serial binary data control signals.
RS485	A standard for defining the electrical characteristics of drivers and receivers for use in a balanced digital multipoint system (also known as EIA-485).
SCU	Surface Control Unit – a specially manufactured computer which is rack mountable and capable of processing the data from the sonar equipment running either Windows XP Embedded or Windows 7 and Seanet Pro or Gemini software.
SeaHub	An alternative to using a Seanet SCU, this device connects to a laptop or PC via USB interface, essentially this takes the signal from the sonar (in RS232, RS485 or ARCNET) and converts it into a signal suitable for the USB port of the computer.
SeaKing	A specific sonar produced by Trittech International Ltd but also refers to the family of sonar equipment manufactured by Trittech International Ltd comprising of the SeaKing, SeaKing DST scanning and profiling sonars and the Hammerhead survey sonar.
Seanet Pro	The software supplied by Trittech International Ltd which is capable of running all the sonar devices.
SeaPrince	A more compact sonar than the SeaKing which operates at a single fixed frequency
Trittech waterblock	The 4000m depth rated connector developed by Trittech International Ltd for their subsea equipment.